



HEATING &amp; AIR CONDITIONING

**TECHNICAL GUIDE****ECHELON™ SERIES****SPLIT SYSTEM  
HEAT PUMPS****20 SEER – R-410A – 1 PHASE****2 THRU 5 NOMINAL TONS****MODELS: HC20B24 THRU 60**

FOR INSTALLATION IN ALL US REGIONS AND CANADA



■ Installation Allowed



Due to continuous product improvement, specifications are subject to change without notice.

Visit us on the web at

[www.upgnet.com](http://www.upgnet.com) and [www.colemanac.com](http://www.colemanac.com)

Additional rating information can be found at

[www.ahridirectory.org](http://www.ahridirectory.org)

**WARRANTY SUMMARY\***

Extended 10-Years limited parts warranty.

Extended Lifetime limited compressor warranty.

**Extended parts and compressor warranties** require online registration within 90 days of purchase for replacement or closing for new home construction.

\*Does not apply to R-22 models, 3-Phase models, or Internet sales.

See Limited Warranty certificate in User's Information Manual for details.

**DESCRIPTION**

The Echelon™ Series HC20 variable capacity heat pumps are the outdoor section of a high efficiency communicating heating and cooling system. They are designed as part of a matched system using an AVV air handler or variable speed communicating furnace with a CM coil. Both the matched CM coil and AVV air handler have factory mounted EEVs. The CM coils with factory mounted EEVs can also be matched with the variable speed MVC modular air handlers.

\*All models in this family are ENERGY STAR® listed as part of a matched system.

**FEATURES**

- **Superior Coil Protection** – An easily removable two-piece steel extruded louver coil guard protects the tube-in-fin coil from debris and physical damage while making access for coil cleaning quick and simple.
- **Environmentally Friendly Refrigerant** – The next generation refrigerant R-410A delivers environmentally friendly performance with zero ozone depletion.
- **Durable Finish** – A high quality powder paint finish rated at 1000 hrs. salt spray provides the ultimate protection from corrosion and harmful UV rays, ensuring a long-lasting, high quality appearance.
- **Charge View™** – A built-in touch screen instantly displays the system conditions, including the system pressures and refrigerant charge without the need to attach additional gauges or sensors.
- **WhisperDrive™ System** – Features a combination of engineered, sound-neutralizing attributes such as a swept-wing fan blade, composite base pan, multi-density compressor cloak and variable capacity operation to reduce sound levels to that of a mere conversation.
- **ECM Fan Motor** – Dynamically adjusts speed in sync with the compressor demand to keep heat exchange in balance while minimizing power consumption and sound.
- **Swept Wing Fan** – A design adapted from aerospace engineering provides whisper-quiet operation by allowing air to flow smoothly and efficiently across the fan surface and edges.
- **Composite Base Pan** – The strong and durable composite base pan is corrosion resistant while adding strength, absorbing sound, and reducing vibration.
- **High-Efficiency Outdoor Coil** – An aluminum fin and copper tube outdoor coil provide easy cleaning, low restriction to airflow and efficient heat exchange.
- **Factory Installed Filter-Drier** – A corrosion resistant, powder painted, stainless steel, solid core, bi-directional liquid line filter-drier removes debris and moisture which can be harmful to the system.
- **Climate Connect™** – provides pre-configured operating profiles the installing contractor can select during set-up to fine tune the system's operation for either Humid, Dry, or Normal climates. Additional fine-tune adjustments are always available to provide a custom comfort solution.
- **Easy Service Access** – A large electrical box cover, independent Charge View access, and a swing open electrical box provide superior full corner access to the inside of the unit for maintenance or service.
- **Dual Fuel Ready** – Using the Echelon Hx™ thermostat, the HC20 will work seamlessly with an communicating 80 or 90% gas furnace to provide the ultimate year round dual fuel comfort solution.

- **System Protection** – All HC20 heat pumps have a factory installed suction accumulator to protect the system from anomalous occurrences. Each system contains high and low pressure transducers which constantly monitor system performance and can alert the consumer or contractor system concerns or alerts.
- **EEV Controls** – All indoor coils, whether in the cased CM coil or in the AVV air handler, have factory installed EEVs (Electronic Expansion Valves). The HC20 outdoor units also employ an EEV to precisely control refrigerant flow, optimizing capacity and efficiency.
- **Communications Capable** – Requiring only 3 thermostat wires between the outdoor and indoor units, the communicating system provides self-commissioning on start-up as well as the ability to check system status at the outdoor unit, thermostat, or remotely using the designated App.
- **Advanced System Control** – The proprietary Wi-Fi Hx™ thermostat interface is an integral part of this innovative system design. Using the Consumer App, consumers can monitor and adjust their system from anywhere in the world using a smart device. Contractors can use the Service App (with homeowner permission), to monitor the system remotely and make adjustments as needed. The system can be configured to provide alerts for emerging issues as well as items that require immediate attention.
- **Variable Capacity Inverter Controlled Scroll Compressor** – Constantly monitors and dynamically adjusts system capacity in precise increments as necessary to closely meet the comfort demands of the conditioned space.
- **Premium System Warranty\*** – Limited lifetime compressor warranty when registered online within 90 days of installation.
- **Agency Listed** – Safety certified by CSA to UL 1995 / CSA 22.2. Performance certified to ANSI/AHRI Standard 210/240 in accordance with the Unitary Small Equipment certification program.

## LIST OF SECTIONS

DESCRIPTION .....	1
FEATURES .....	1
LIST OF SECTIONS .....	2
NOMENCLATURE .....	2
PHYSICAL AND ELECTRICAL DATA .....	3
DIMENSIONS .....	3
SYSTEM CHARGE FOR VARIOUS MATCHED SYSTEMS .....	4
LIMITATIONS .....	5
SYSTEM CAPACITY - Single Piece and Modular Air Handlers ...	6
SYSTEM CAPACITY - With High Efficiency Motor Furnaces ...	7
ACCESSORIES .....	8
SOUND POWER RATINGS - COOLING .....	8
SOUND POWER RATINGS - HEATING .....	8
UNIT OPERATION .....	8
MECHANICAL SPECIFICATIONS .....	9
TYPICAL INSTALLATION .....	10
TYPICAL FIELD WIRING .....	11
ALTERNATIVE INSTALLATION CLEARANCES .....	11
PERFORMANCE DATA - 2 TON .....	12
PERFORMANCE DATA - 3 TON .....	14
PERFORMANCE DATA - 4 TON .....	16

## NOMENCLATURE

PRODUCT TYPE	H	A = Premium Heat Pump
BRAND	C	C = Coleman
NOMINAL SERIES EFFICIENCY AND STAGING	20	21 = 20 SEER / Modulating
REFRIGERANT	B	B = R-410A
NOMINAL UNIT CAPACITY (MBH)	36	24 = 2 Ton      48 = 4 Ton 36 = 3 Ton      60 = 5 Ton
VOLTAGE (Voltage-Phase-Hertz)	2	2 = 208/230-1-60
GENERATION (MAJOR REVISION)	1	1 = 1st Gen 2 = 2nd Gen etc
FACTORY OPTION	S	S = Standard (No Options) H = Hard Start Kit
STYLE LETTER (MINOR REVISION) NOT USED FOR ORDERING	A	A = Style A B = Style B etc

## PHYSICAL AND ELECTRICAL DATA

MODEL		HC20B2421S	HC20B3621S	HC20B4821S	HC20B6021S
Unit Supply Voltage		208-230V, 1 $\phi$ , 60Hz			
Normal Voltage Range <sup>1</sup>		187 to 252			
Minimum Circuit Ampacity		17.7	25.7	28.6	33.9
Max. Overcurrent Device Amps <sup>2</sup>		30.0	40.0	45.0	50.0
Compressor	Type	Scroll	Scroll	Scroll	Scroll
	Rated Load	16.0	19.2	21.2	24.4
	Locked Rotor	35.0	35.0	35.0	50.0
Crankcase Heater		Yes	Yes	Yes	Yes
HS Kit Required with TXV		N/A	N/A	N/A	N/A
Fan Diameter Inches		24	24	26	26
Fan Motor	Rated HP	1/4	1/4	1/3	1/3
	Rated Load Amps	1.7	1.7	2.6	2.6
	Nominal RPM	850	1025	975	1050
	Nominal CFM	3200	3900	4800	5300
Coil	Face Area Sq. Ft.	23.82	23.82	31.2	31.2
	Rows Deep	1	2	2	2
	Fins / Inch	22	18	18	18
Liquid Line Set OD (Field Installed)		3/8	3/8	3/8	3/8
Vapor Line Set OD (Field Installed) <sup>3,4</sup>		3/4	3/4	7/8	1-1/8**‡
Unit Charge (Lbs. - Oz.) <sup>5</sup>		8 - 2	12 - 10	17 - 6	16 - 9
Charge Per Foot, Oz.		0.62	0.62	0.67	0.75
Operating Weight Lbs.		242	259	292	304

1. Rated in accordance with AHRI Standard 110-2012, utilization range "A".
2. Dual element fuses or HACR circuit breaker. Maximum allowable overcurrent protection.
3. For applications with non-standard vapor line sizes, see the "Applications & Accessories" section of this Technical Guide.
4. (\*\*) denotes the 7/8" lineset required if line is over 25' or if there is any vertical rise.  
(‡) denotes the adapter fitting must be field installed for a 1-1/8" line set.
5. The Unit Charge is correct for the outdoor unit, smallest matched indoor unit, and 15 feet of refrigerant tubing. For tubing lengths other than 15 feet, add or subtract the amount of refrigerant, using the difference in actual lineset length (not the equivalent length) multiplied by the per foot value.

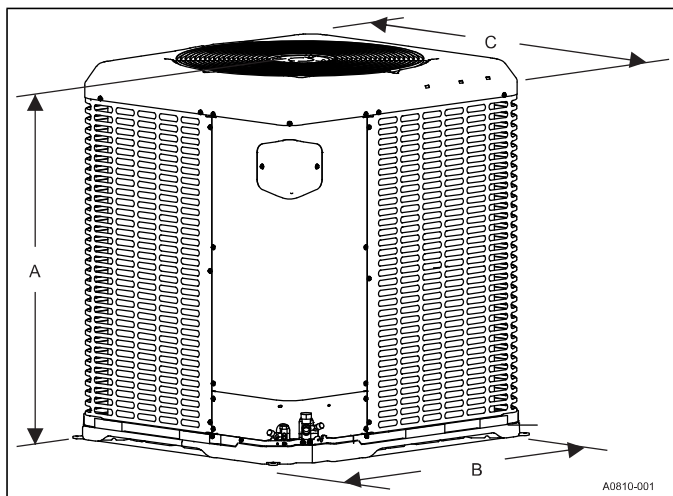

## DIMENSIONS

Unit Model	Dimensions (Inches)			Refrigerant Connection Service Valve Size	
	A	B	C	Liquid	Vapor
HC20B2421S	40-1/4	35-1/2	32	3/8	3/4
HC20B3621S	40-1/4	35-1/2	32		
HC20B4821S	46-1/2	38-1/4	34-1/2		7/8
HC20B6021S	46-1/2	38-1/4	34-1/2		7/8**‡

\*\* 7/8" lineset required if line is over 25' or if there is any vertical rise.  
 ‡ Adapter fitting must be field installed for a 1-1/8" line set.  
 All dimensions are in inches and are subject to change without notice.  
 Overall height is from bottom of base pan to top of fan guard.  
 Overall length and width include screw heads.

**SYSTEM CHARGE FOR VARIOUS MATCHED SYSTEMS**

Outdoor Unit	HC20B2421S	HC20B3621S	HC20B4821S	HC20B6021S
<b>Indoor Unit <sup>1</sup></b>	<b>Additional Charge, oz.</b>			
AVV25BE121	0	–	–	–
AVV38CE221	–	0	–	–
AVV50CE321	–	–	0	–
AVV50DE321	–	–	0	–
AVV61CE421	–	–	–	0
AVV61DE421	–	–	–	0
CM25BE1A1	0	–	–	–
CM38CE2A1	–	0	–	–
CM50CE3A1	–	–	0	–
CM50DE3A1	–	–	0	–
CM61CE4A1	–	–	–	0
CM61DE4A1	–	–	–	0

All of the combinations shown in the above System Charge table require Advanced Main Air Circulating Fan indoor product. "Coil Only" matches are not available for these systems.

**FOOTNOTES:**

- Charge adders shown above do not indicate that coils are rated for every application. Refer to Performance Data Tables for actual performance for specified system matches. Obtain certified system ratings from [www.ahridirectory.org](http://www.ahridirectory.org).

**CHARGING PROCEDURES:**

- Determine outdoor unit factory charge from Tabular Data Sheet.
- Determine indoor coil adjustment (if any) from Tabular Data Sheet.
- Calculate the additional charge for refrigerant piping using this Tabular Data Sheet if line length is greater than 15 feet (4.6 m).
- Total system charge = item 1 + item 2 + item 3.
- The manifold gauge set is already installed on the unit for evacuation and charging. Use these gauges to initially charge the system using system pressures and subcooling. Before charging put the equipment into "Service Mode" at the outdoor control. You will find the charging information printed on the bottom of the unit data tag. More charging information is available in the "Service Data Application Guide", available online. For subsequent annual maintenance visits the charge verification display can be used to quickly check overall system condition and the system charge without attaching a separate manifold gauge set or temperature sensors.
- Permanently mark the unit data plate with the total amount of refrigerant in the system.

**IMPORTANT**

*It is recommended before starting the system to connect the thermostat to Wi-Fi using a local network or portable hot-spot so the thermostat and system receive the latest software updates to optimize system performance.*

## LIMITATIONS

The unit should be installed in accordance with all National, State and Local Safety Codes and the limitations listed below:

1. Limitations for the indoor unit, coil, and appropriate accessories must also be observed.
2. The outdoor unit must not be installed with any duct work in the air stream. The outdoor fan is the propeller type and is not designed to operate against any additional external static pressure.
3. The maximum and minimum conditions for operation must be observed to ensure a system will give maximum performance with minimal service.

### Minimum / Maximum Operating Limit Conditions

AIR TEMPERATURE AT OUTDOOR COIL, °F (°C)				AIR TEMPERATURE AT INDOOR COIL, °F (°C)			
Min.		Max.		Min.		Max.	
DB Cool	DB Heat	DB Cool	DB Heat	WB Cool	DB Heat	WB Cool	DB Heat
35(2)*	-5(-21)	125(52)*	75(24)	57(14)	50(10)	72(22)	80(27)

\*Reference the NOTICE under the "Unit Reduced Capacity Conditions" section.

4. The maximum allowable equivalent line length for this product is 80 feet.

### Standard Lineset Applications

Maximum allowable lineset varies depending on the vertical separation between the evaporator and condenser. See Table 2 for allowable line set lengths and sizing.

### Allowable Vertical Linesets

Model	Liquid Line	Suction Line	Max Line Length Units on Equal Level	Max Suction Line Riser - If OD Unit is Above ID Unit	Max Liquid Line Riser - If OD Unit is Below ID Unit
24	3/8"	3/4"	80 feet	25 feet	25 feet
36					
48		7/8"			
60		‡1-1/8"			

‡ 7/8" lineset required if line length is over 25' or if there is any vertical rise.

## Unit Reduced Capacity Conditions

# NOTICE

### Inverter Temperature Protection

If excessive inverter temperatures are sensed, the compressor speed / capacity is reduced until an acceptable condition is reached.

When the inverter temperature returns to an acceptable level, the system returns to normal operation.

**Over / Under Current Protection:** If a low or high Current Condition is sensed, the compressor speed / capacity is reduced until an acceptable current level is reached.

When the system reaches an acceptable current level, the compressor and fan return to normal operating conditions.

**Over / Under Voltage Protection:** If a low or high supply Voltage Condition is experienced (below 187 VAC or above 265 VAC), the compressor speed / capacity is automatically reduced until an acceptable voltage level is sensed.

When an acceptable voltage level is sensed, the system automatically returns to a normal state of operation.

**High Altitude Protection:** If the unit is installed in Altitudes of 6,500 ft / 2,000 m above sea level or higher, the compressor and outdoor fan reduce speeds to protect the system. It is not recommended these units be installed at altitudes greater than 6,500 ft / 2,000 m above sea level.

### Low Ambient Protection

**Cooling Mode:** The unit automatically adjusts to maintain cooling operation in outdoor ambient conditions down to 35° F (2° C). The unit reduces capacity and Low Ambient Protection (cooling mode) or cycles off if asked to provide cooling when the outdoor temperature is at or below these conditions.

**Heating Mode:** The unit provides compressor heat down to an outdoor ambient temperature of -5° F (-29° C). As the outdoor ambient temperature reduces, available heat reduces for all air source heat pumps. Make sure the balance point and auxiliary heat are appropriately set and sized for the application of the heat pump.

## SYSTEM CAPACITY - Single Piece and Modular Air Handlers

UNIT MODEL	AIR HANDLER		COIL MODEL <sup>3</sup>	Stage	RATED CFM	COOLING <sup>1</sup>			HEATING <sup>2</sup>						
	MODEL	WIDTH				NET MBH TOTAL	SENS.	SEER	EER	NET MBH		HSPF IV	HSPF V	COP	
										47°F OD	17°F OD			47°F OD	17°F OD
HC20B2421S	AVV25BE12	17.5	-	High	740	23.6	16.7	19.40	13.65	34.4	22.6	11.00	9.25	3.86	2.22
				Med	610	14.0	11.5	-	18.55	-	-	-	-	-	-
				Low	395	7.9	6.6	-	33.50	-	-	-	-	-	-
HC20B2421S	MVC12BN21	17.5	CM25BE1A1	High	700	23.4	17.4	19.25	13.25	32.8	22.6	11.00	9.05	2.84	2.22
				Med	575	13.8	12.0	-	18.35	-	-	-	-	-	-
				Low	325	8.3	6.6	-	32.80	-	-	-	-	-	-
HC20B3621S	AVV38CE22	21.0	-	High	1160	34.6	27.4	20.00	14.15	50.0	32.4	11.00	8.65	3.00	2.30
				Med	761	20.2	17.0	-	18.95	-	-	-	-	-	-
				Low	369	11.4	8.8	-	37.15	-	-	-	-	-	-
HC20B3621S	MVC16CN21	21.0	CM38CE2A1	High	1175	34.4	26.8	19.00	13.75	47.5	32.4	10.50	8.75	2.98	2.28
				Med	550	19.1	14.1	-	17.60	-	-	-	-	-	-
				Low	400	11.3	9.0	-	35.65	-	-	-	-	-	-
HC20B4821S	AVV50CE32	21.0	-	High	1550	45.0	35.2	19.25	12.50	59.0	44.5	10.25	8.10	3.26	2.32
				Med	925	27.0	22.8	-	18.25	-	-	-	-	-	-
				Low	600	17.6	15.8	-	34.05	-	-	-	-	-	-
HC20B4821S	AVV50DE32	24.5	-	High	1555	45.0	36.0	19.30	13.10	62.0	44.5	10.50	8.20	3.28	2.34
				Med	874	26.8	21.8	-	18.60	-	-	-	-	-	-
				Low	570	17.6	15.5	-	37.20	-	-	-	-	-	-
HC20B4821S	MVC16CN21	21.0	CM50CE3A1	High	1550	45.0	35.2	19.50	12.50	59.0	44.5	10.25	7.95	3.26	2.32
				Med	925	27.0	22.8	-	18.25	-	-	-	-	-	-
				Low	700	17.6	14.2	-	34.85	-	-	-	-	-	-
HC20B4821S	MVC20DN21	24.5	CM50DE3A1	High	1575	45.0	35.4	19.50	12.50	59.0	44.0	10.25	8.20	3.28	2.30
				Med	921	27.0	22.6	-	18.35	-	-	-	-	-	-
				Low	642	17.8	16.4	-	35.45	-	-	-	-	-	-
HC20B6021S	AVV61CE421	21.0	-	High	1600	53.0	37.6	18.25	12.25	67.0	48.0	10.00	8.10	3.06	2.36
				Med	850	30.8	22.4	-	18.55	-	-	-	-	-	-
				Low	700	19.8	16.0	-	35.35	-	-	-	-	-	-
HC20B6021S	AVV61DE421	24.5	-	High	1670	53.0	38.5	18.80	12.60	71.0	49.0	10.50	9.00	3.78	2.38
				Med	920	31.2	22.0	-	18.45	-	-	-	-	-	-
				Low	740	18.4	14.6	-	34.85	-	-	-	-	-	-
HC20B6021S	MVC20DN21	24.5	CM61DE4A1	High	1775	52.5	38.5	18.50	12.25	67.0	49.0	10.00	8.30	2.96	2.36
				Med	800	30.4	21.4	-	18.15	-	-	-	-	-	-
				Low	650	19.5	15.2	-	34.35	-	-	-	-	-	-

Rated in accordance with DOE test procedures (Federal Register 12-27-79 and 3-18-88) and ANSI/AHRI Standard 210/240.

1. Cooling MBH based on 80°F entering air temperature, 50% RH (Relative Humidity), and rated air flow.

EER (Energy Efficiency Ratio) is the total cooling output in BTUs at 95°F outdoor ambient divided by the total electric power in watt-hours at those conditions.

SEER (Seasonal Energy Efficiency Ratio) is the total cooling output in BTUs during a normal annual usage period for cooling divided by the total electric power input in watt-hours during the same period.

2. Heating MBH based on AHRI standards of 70°F DB (Dry Bulb) entering indoor air, 72% RH (Relative Humidity) outdoor air with 25 feet of interconnecting piping and no supplemental electric heat operation.

HSPF (Heating Seasonal Performance Factor) is the total heating output during a normal annual usage period for heating divided by the total electric power input during the same period.

COP (Coefficient of Performance) equals Heating MBH output divided by (total KW input x 3.412).

— = Not applicable.

CM coils available with a factory installed horizontal drain pan. See price pages for specific model number.

**SYSTEM CAPACITY - With High Efficiency Motor Furnaces<sup>1</sup>**

UNIT MODEL	FURNACE		COIL MODEL	Stage	COOLING				HEATING					
	MODEL	WIDTH			RATED CFM	NET MBH		SEER	EER	NET MBH 47°F OD 17°F OD	HSPF IV	HSPF V	COP	
						TOTAL	SENS.						47°F OD	17°F OD
HC20B2421S	TM9V060B12MP11	17.5	800	24.0	18.8	18.75	12.25	32.8	22.4	11.00	8.05	2.74	2.14	
			575	14.2	12.4	-	17.90	-	-	-	-	-	-	-
			356	8.7	7.3	-	31.75	-	9.1	-	-	-	4.38	-
HC20B2421S	TM9V080B12MP11	17.5	800	24.0	18.8	18.75	12.25	32.8	22.4	11.00	8.05	2.74	2.14	
			575	14.2	12.4	-	17.90	-	-	-	-	-	-	-
			356	8.7	7.3	-	31.75	-	9.1	-	-	-	4.38	-
HC20B2421S	TP9C060B12MP12	17.5	800	24.0	18.8	18.75	12.25	32.8	22.4	11.00	8.05	2.74	2.14	
			575	14.2	12.4	-	17.90	-	-	-	-	-	-	-
			356	8.7	7.3	-	31.75	-	9.1	-	-	-	4.38	-
HC20B2421S	TP9C080B12MP12	17.5	800	24.0	18.8	18.75	12.25	32.8	22.4	11.00	8.05	2.74	2.14	
			575	14.2	12.4	-	17.90	-	-	-	-	-	-	-
			356	8.7	7.3	-	31.75	-	9.1	-	-	-	4.38	-
HC20B2421S	CP9C060B12MP12	17.5	800	24.0	18.8	18.75	12.25	32.8	22.4	11.00	8.05	2.74	2.14	
			575	14.2	12.4	-	17.90	-	-	-	-	-	-	-
			356	8.7	7.3	-	31.75	-	9.1	-	-	-	4.38	-
HC20B2421S	CP9C080B12MP12	17.5	800	24.0	18.8	18.75	12.25	32.8	22.4	11.00	8.05	2.74	2.14	
			575	14.2	12.4	-	17.90	-	-	-	-	-	-	-
			356	8.7	7.3	-	31.75	-	9.1	-	-	-	4.38	-
HC20B3621S	TM9V080C16MP11	21.0	1250	35.8	28.2	19.75	13.75	47.5	32.4	10.75	8.45	2.92	2.24	
			700	20.0	16.1	-	18.60	-	-	-	-	-	-	-
			351	11.3	8.6	-	35.65	-	11.6	-	-	-	4.50	-
HC20B3621S	TM9V100C16MP11	21.0	1250	35.8	28.2	19.75	13.75	47.5	32.4	10.75	8.45	2.92	2.24	
			700	20.0	16.1	-	18.60	-	-	-	-	-	-	-
			351	11.3	8.6	-	35.65	-	11.6	-	-	-	4.50	-
HC20B3621S	TP9C080C16MP12	21.0	1250	35.8	28.2	19.75	13.75	47.5	32.4	10.75	8.45	2.92	2.24	
			700	20.0	16.1	-	18.60	-	-	-	-	-	-	-
			351	11.3	8.6	-	35.65	-	11.6	-	-	-	4.50	-
HC20B3621S	TP9C100C16MP12	21.0	1250	35.8	28.2	19.75	13.75	47.5	32.4	10.75	8.45	2.92	2.24	
			700	20.0	16.1	-	18.60	-	-	-	-	-	-	-
			351	11.3	8.6	-	35.65	-	11.6	-	-	-	4.50	-
HC20B3621S	CP9C080C16MP12	21.0	1250	35.8	28.2	19.75	13.75	47.5	32.4	10.75	8.45	2.92	2.24	
			700	20.0	16.1	-	18.60	-	-	-	-	-	-	-
			351	11.3	8.6	-	35.65	-	11.6	-	-	-	4.50	-
HC20B3621S	CP9C100C16MP12	21.0	1250	35.8	28.2	19.75	13.75	47.5	32.4	10.75	8.45	2.92	2.24	
			700	20.0	16.1	-	18.60	-	-	-	-	-	-	-
			351	11.3	8.6	-	35.65	-	11.6	-	-	-	4.50	-

1. High Efficiency Motor Furnaces have B.O.D. (Blower on Delay) standard.

## ACCESSORIES

**Support Feet S1-HPRKIT-\*\*:** Kit of 5 support feet to raise unit above snow or landscaping. Available in heights of 3", 6" or 12".

**Anchor Bracket Kit S1-1HK0401:** Firmly anchors unit to pad or support structure. When properly installed, approved for ground-mounted or roof-mounted applications.

**Wall Mount Kit (S1-ACB-\*\*):** Includes two brackets to allow outdoor unit to be securely mounted to a vertical wall. Mounting hardware is field sourced according to the specific application.

**Touch-up Paint S1-5130153\*\*\*\*:** Color matched aerosol paint for touching up unit chassis and panels. See Price Pages or Source1 SmartSearch for the correct color for each application.

**Thermostat:** Compatible thermostat controls are available through accessory sourcing. For optimum performance, these outdoor units are fully compatible with our Coleman residential touch screen thermostat with proprietary (patent-pending) hexagon interface. For more information, see the thermostat section of the Product Equipment Catalog.

## SOUND POWER RATINGS - COOLING

High Stage Cooling	Octave Band Sound Power Level (db re. 1-pW)									
Model Number	63	125	250	500	1000	2000	4000	8000	dBA	SQI
HC20B2421S	68	70	66	66	64	60	58	52	69	19.1
HC20B3621S	71	71	67	68	65	61	57	52	70	19.2
HC20B4821S	73	77	74	72	70	65	62	54	75	19.0
HC20B6021S	70	77	72	73	71	64	59	56	75	19.0
Low Stage Cooling	Octave Band Sound Power Level (db re. 1-pW)									
HC20B2421S	64	64	51	50	49	43	37	41	54	19.1
HC20B3621S	64	65	54	52	49	44	41	39	55	19.1
HC20B4821S	64	65	66	58	55	52	43	39	63	19.1
HC20B6021S	66	65	68	61	58	48	41	42	64	19.0

Rated in accordance with ARI Standard 270.

## SOUND POWER RATINGS - HEATING

High Stage Heating	Octave Band Sound Power Level (db re. 1-pW)									
Model Number	63	125	250	500	1000	2000	4000	8000	dBA	SQI
HC20B2421S	69	66	60	65	59	57	53	51	66	19.1
HC20B3621S	73	67	68	66	62	57	53	51	67	19.0
HC20B4821S	68	68	70	68	65	62	57	55	70	19.1
HC20B6021S	71	76	70	69	69	63	58	54	72	19.1
Low Stage Heating	Octave Band Sound Power Level (db re. 1-pW)									
HC20B2421S	63	63	53	52	50	41	38	40	54	19.2
HC20B3621S	65	63	55	55	48	41	36	39	55	19.0
HC20B4821S	63	63	60	59	49	41	38	41	58	19.0
HC20B6021S	67	66	61	62	61	55	50	51	64	19.1

Rated in accordance with ARI Standard 270.

## UNIT OPERATION

### DEFROST MODE

The defrost mode is equivalent to the cooling mode except that the outdoor fan motor is de-energized.

If the call for heating is removed from the control during the defrost cycle, the system will terminate the defrost cycle. The system will also stop the "Defrost Cycle Timer" but not reset it. When the system receives another call for compressor heating, it will restart the defrost cycle and the "Defrost Cycle Timer" at the point at which the call for heating was removed; if the conditions requiring a defrost still remain (coil temperature is below 35°F).

The system will remember what compressor speed and where in the operational algorithm the system is being operated before initiating a defrost. The system will run the "Defrost Compressor Speed" for the given tonnage. The system will run the "Calibrated Compressor Speed" during calibration.

- The system will do the following to initiate a defrost cycle.
- Record the Outdoor EEV Setpoint.
- Record the Calibrated Compressor Speed and where in the operational algorithm the system is.
- The Suction Pressure Fault is ignored during defrost unless the Absolute Trip value is < 5psi., then the fault is recognized as active.
- Communicate proper speed of compressor "Defrost Compressor Speed".
- Communicate proper speed of ID CFM for the "Defrost ID Airflow".
- Communicate the Outdoor Fan speed to 0.
- Energize the reversing valve.
- Fully open the Outdoor EEV.
- Communicate proper Indoor EEV Setpoint "ID EEV Setpoint".
- Begin the "Defrost Cycle Timer".
- Communicate the W1OUT for auxiliary heat.



## MECHANICAL SPECIFICATIONS

### MANUFACTURE AND CERTIFICATIONS

- Units shall be manufactured in an ISO 9001 certified facility.
- Units shall be certified by CSA to UL 1995 / CSA 22.2 and performance certified to ANSI/AHRI Standard 210/240.
- Units shall be sound tested according to ANSI/AHRI Standard 270.
- Certified matched system ratings will be available for download from the AHRI online directory at [www.ahridirectory.org](http://www.ahridirectory.org).
- Unit packaging shall be marked, "Assembled in the USA".
- Unit shall be labeled with the ENERGY STAR logo.
- Unit shall be recognized as ENERGY STAR Most Efficient. (May apply only to select models in each series).

### UNIT APPLICATION

- Units shall be approved for cooling operation between 35°F and 125°F without modification.
- Units shall be approved for heating operation between -5°F and 75°F without modification.
- Units shall be approved for linesets up to 80 feet equivalent length without modification.
- Units shall be approved for installation within 6 inches of a flat vertical wall without modification, according to the instructions in the technical literature.
- Units shall be certified to the 5th Edition (2014) of the Florida Building Code for both Ground Mounted and Rooftop Mounted applications up to 200 feet above grade with approved mounting kit.

### UNIT ACCESS

- Units shall have a removable fan guard that can be removed independently of the top for interior access through the top of the unit without damaging the coil.
- Units shall have two removable stamped steel coil guards for exterior coil access.
- Units shall have a separate compartment for electrical controls that can be accessed without disturbing the unit airflow.
- Units shall have a blockoff panel that can be removed to provide interior unit access through the side of the unit.
- Units shall have a removable blockoff panel and a swing away removable electrical panel that provides sufficient interior unit access for removing the compressor through the side of the unit.

## UNIT CONSTRUCTION

- Units shall be shipped completely wired, piped and assembled. Wiring pigtails shall be provided for field control wiring connections. Service valves shall be provided for field refrigerant line connections.
- Units shall be factory leak checked, run tested, and shipped with a holding charge of R-410A refrigerant.
- Unit cabinet components shall be G90 equivalent steel finished with powder-coat paint rated at a minimum of 1,000 hours under ASTM B117 testing.
- Unit shall be constructed with a composite base pan to prevent corrosion and minimize noise and vibration.
- Units shall have a single corner post opposite the electrical control box and two independently removable steel coil guard panels to optimize cabinet strength and serviceability.
- Units shall have L-shaped stamped sheet metal coil guards with extruded louvers for maximum panel durability and system protection.
- Units shall have a factory installed bi-directional stainless steel filter-drier for faster installation and improved system reliability.
- Unit base valves shall be mounted diagonally on the unit base pan with service ports that provide sufficient clearance for low-loss hose fittings.
- Units shall be constructed with a high pressure switch and a low pressure for system protection.
- Units shall be constructed with all badging and labels applied at the factory.

## UNIT COMPONENTS

- Compressor shall be hermetic with internal electrical overload protection and internal overpressure protection.
- Compressor shall be mounted on rubber vibration isolators that do not require the removal of transportation clips or brackets.
- Units shall be constructed using a scroll compressor paired with an inverter drive.
- Condenser fan shall be direct drive with vertical air discharge for low sound levels.
- Condenser fan blades shall be swept-wing to minimize sound.
- Condenser fan motor shall be ECM construction with permanently lubricated ball bearing motors approved for vertical shaft applications.
- Condenser coil shall be air cooled and constructed of enhanced aluminum fins mechanically bonded to internally enhanced Ø 7mm copper tubing.

## UNIT WARRANTIES

- Unit manufacturer shall provide a Limited Lifetime compressor warranty with unit registration.
- Unit manufacturer shall provide a limited 5-Year parts warranty extended to 10 years with registration.

**TYPICAL INSTALLATION**

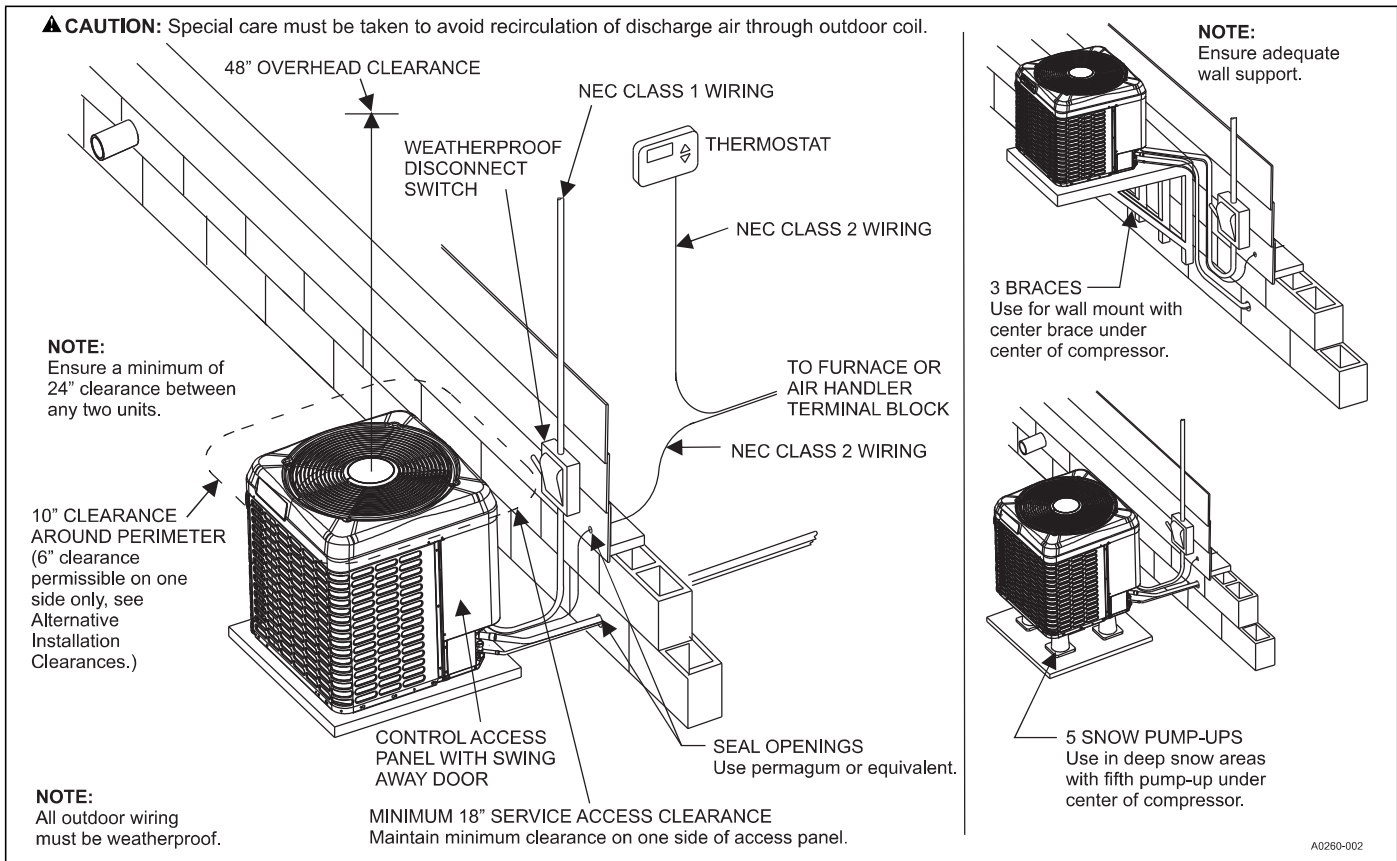

**▲ CAUTION**

*Care must be taken to prevent ice from damaging the unit. Damage may occur from ice falling onto unit from a sloped roof or from a vertical drip line due to a partial overhang.*

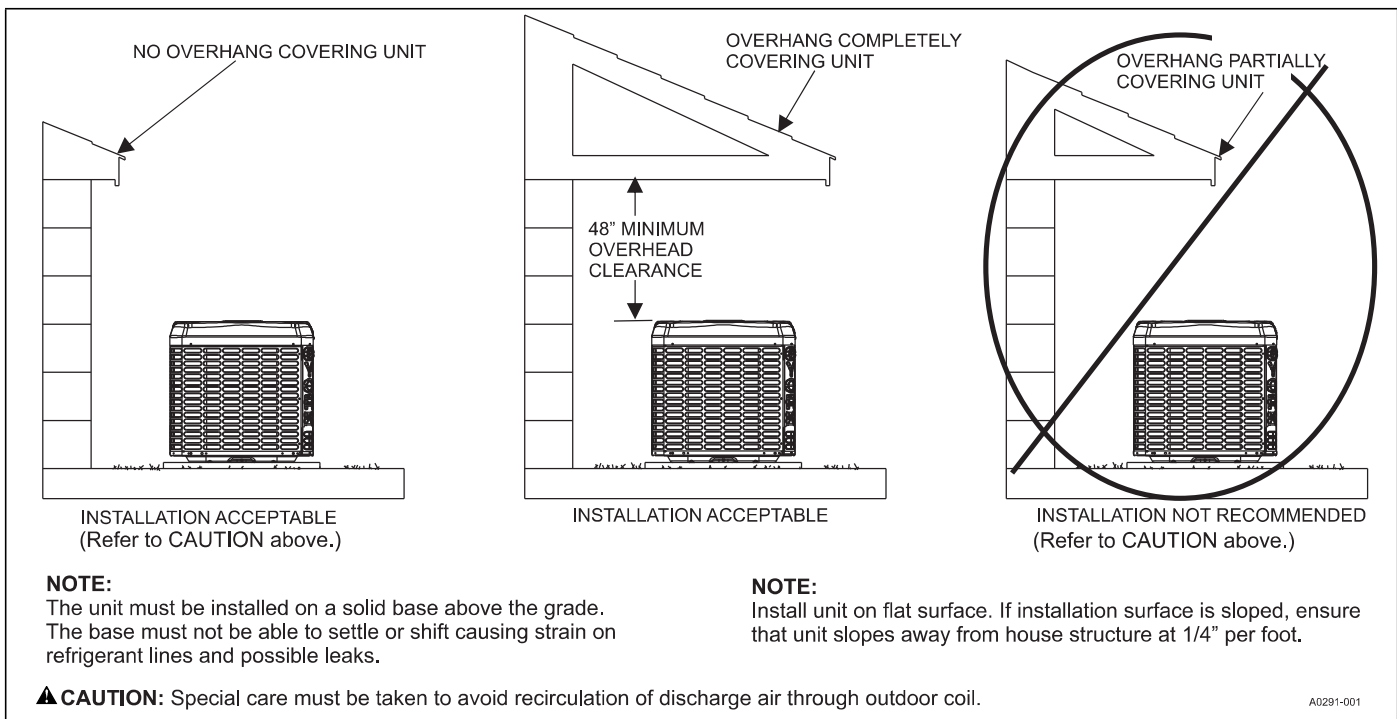

**TYPICAL FIELD WIRING**

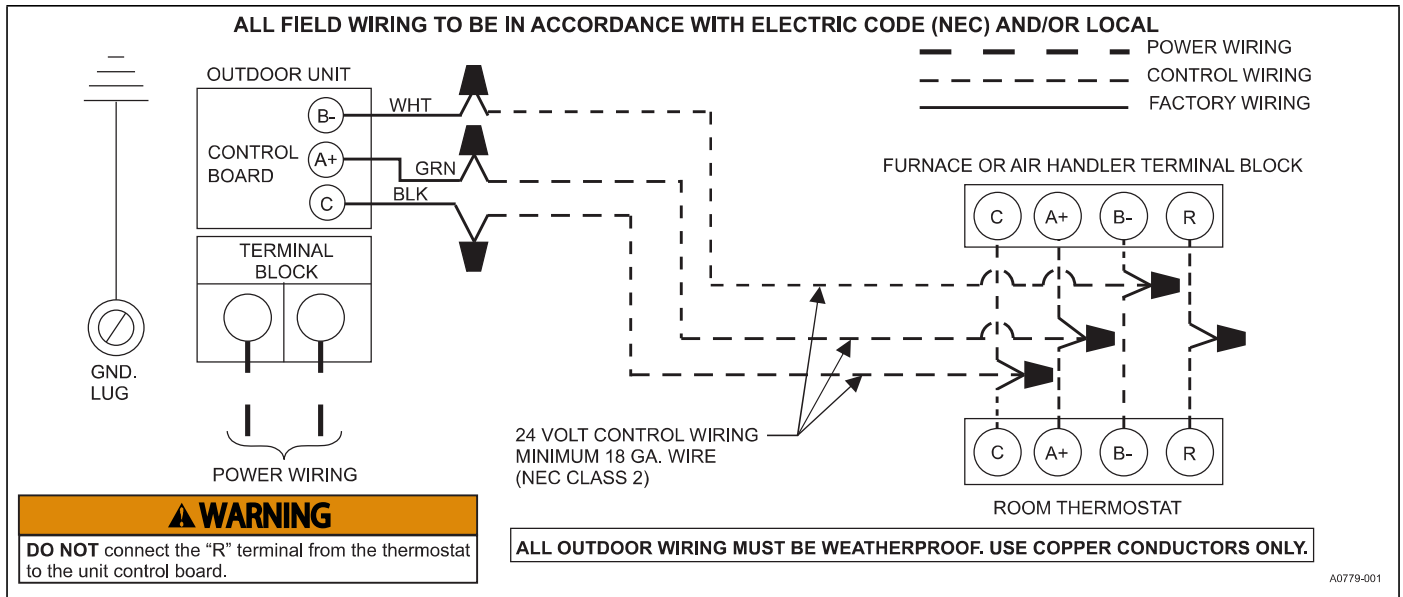

**ALTERNATIVE INSTALLATION CLEARANCES**

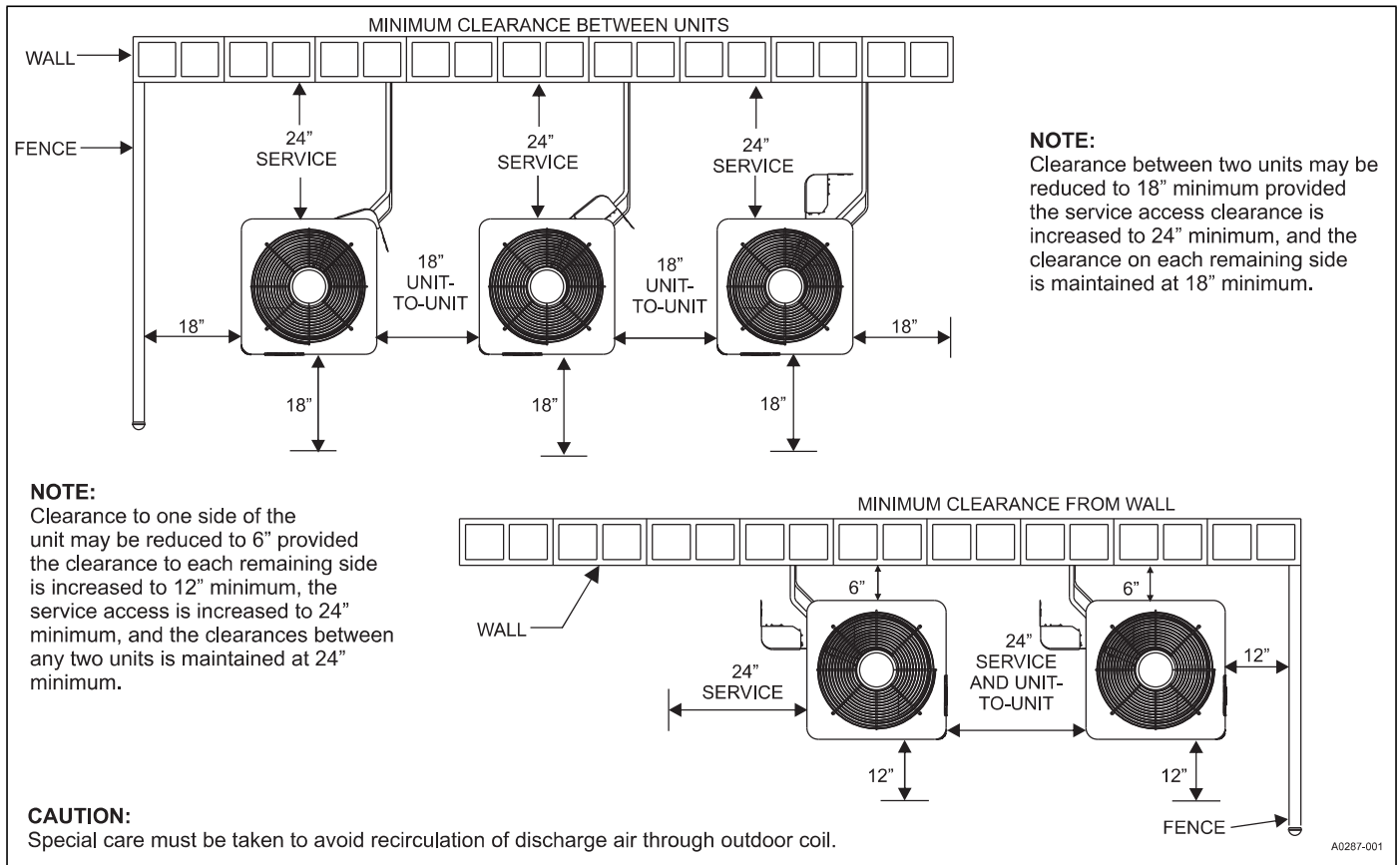

## PERFORMANCE DATA - 2 TON

COOLING PERFORMANCE DATA- HIGH																
AIR CONDITIONER MODEL NO.		HC20B2421S														
AIR TEMP. ENTERING OUTDOOR UNIT (°F)	IDCFM	680					780					880				
	ID DB (°F)	80	80	75	80	80	80	80	75	80	80	80	80	75	80	80
	ID WB (°F)	57	62	62	67	72	57	62	62	67	72	57	62	62	67	72
55	T.C.	19.6	20.3	20.3	22.2	24.3	20.1	21.4	20.6	22.5	24.5	20.6	22.4	20.8	22.8	24.7
	S.C.	19.4	19.3	15.5	15.7	12.7	20.0	20.0	15.9	16.2	13.0	20.6	20.6	16.3	16.8	13.3
	KW	0.71	0.71	0.71	0.68	0.63	0.74	0.73	0.74	0.70	0.66	0.76	0.75	0.76	0.72	0.68
65	T.C.	19.7	20.9	21.0	23.1	25.5	20.4	21.7	21.4	23.5	26.0	21.1	22.4	21.9	24.0	26.4
	S.C.	19.4	19.3	15.6	15.8	12.7	20.1	20.0	16.1	16.4	13.1	20.9	20.6	16.6	17.1	13.5
	KW	1.03	0.95	0.95	0.91	0.87	1.01	0.97	0.98	0.93	0.89	0.99	0.99	1.00	0.96	0.92
75	T.C.	19.7	21.6	21.6	24.0	26.7	20.6	22.0	22.2	24.6	27.4	21.5	22.5	22.9	25.1	28.1
	S.C.	19.4	19.3	15.7	15.9	12.7	20.3	20.0	16.3	16.6	13.1	21.2	20.7	16.9	17.3	13.6
	KW	1.35	1.19	1.18	1.14	1.10	1.29	1.21	1.21	1.17	1.13	1.23	1.23	1.25	1.20	1.16
85	T.C.	19.8	22.2	22.2	24.9	27.4	20.8	22.5	23.1	25.6	28.0	21.9	22.7	23.9	26.3	28.6
	S.C.	19.4	19.3	15.9	16.0	13.2	20.4	20.0	16.5	16.8	13.5	21.5	20.7	17.2	17.6	13.7
	KW	1.55	1.47	1.46	1.43	1.40	1.53	1.49	1.49	1.46	1.43	1.51	1.52	1.53	1.49	1.46
95	T.C.	19.8	22.9	22.8	25.7	28.1	21.1	22.9	23.9	26.6	28.6	22.3	22.9	25.0	27.5	29.1
	S.C.	19.4	19.3	16.0	16.1	13.8	20.6	20.0	16.7	17.0	13.8	21.8	20.7	17.5	17.8	13.8
	KW	1.74	1.74	1.74	1.73	1.71	1.77	1.77	1.77	1.75	1.73	1.80	1.80	1.80	1.78	1.76
105	T.C.	19.9	23.5	23.5	26.6	28.8	21.1	23.3	24.8	27.6	29.2	22.3	23.1	26.1	28.6	29.6
	S.C.	19.4	19.3	16.1	16.2	14.4	20.4	20.1	17.0	17.2	14.1	21.4	21.0	17.8	18.1	13.9
	KW	2.08	2.11	2.15	2.15	2.15	2.20	2.21	2.19	2.18	2.18	2.32	2.31	2.22	2.22	2.22
115	T.C.	19.9	24.1	24.1	27.5	29.5	21.1	23.7	25.6	28.7	29.8	22.3	23.3	27.1	29.8	30.1
	S.C.	19.4	19.3	16.3	16.3	14.9	20.2	20.3	17.2	17.3	14.5	21.1	21.2	18.1	18.3	14.0
	KW	2.41	2.47	2.55	2.56	2.59	2.61	2.64	2.58	2.60	2.62	2.81	2.81	2.62	2.64	2.65
125	T.C.	20.0	24.8	24.7	28.4	30.2	21.1	24.1	26.4	29.7	30.4	22.3	23.5	28.1	30.9	30.6
	S.C.	19.4	19.3	16.4	16.4	15.5	20.1	20.4	17.4	17.5	14.8	20.7	21.4	18.4	18.6	14.1
	KW	2.74	2.83	2.95	2.97	3.02	3.03	3.07	2.98	3.02	3.06	3.31	3.31	3.02	3.07	3.09

NOTE: ALL CAPACITIES INCLUDE INDOOR FAN HEAT. KW VALUES ARE FOR THE SYSTEM (OUTDOOR + INDOOR).

Green shaded cells are ACCA (TVA) conditions.

Blue shaded cells are AHRI conditions.

## Multipliers for determining the performance with other indoor sections.

NOTE: For dry bulb temperatures different than those listed (between 73-87 °F), sensible capacity increases by 1060 BTUH per 1000 CFM per degree above the listed temperature and decreases by 1060 BTUH per 1000 CFM per degree below the listed temperature.

## COIL MULTIPLIERS - 2 TON

Air Handler	Coil	T.C.	S.C.	KW
AVV25BE12	—	1.00	1.00	1.00
MVC12BN21	CM25BE1A1	0.99	1.04	1.02

## FURNACE MULTIPLIERS - 2 TON

Furnaces	Coil	T.C.	S.C.	KW
TM9V060B12MP11	CM25BE1A1	1.02	1.12	1.13
TM9V080B12MP11	CM25BE1A1	1.02	1.12	1.13
TP9C060B12MP12	CM25BE1A1	1.02	1.12	1.13
TP9C080B12MP12	CM25BE1A1	1.02	1.12	1.13
CP9C060B12MP12	CM25BE1A1	1.02	1.12	1.13
CP9C080B12MP12	CM25BE1A1	1.02	1.12	1.13

HEATING PERFORMANCE DATA - HIGH										
CONDENSING UNIT MODEL NO		HC20B2421S								
AIR TEMP. ENTERING OUTDOOR UNIT (°F)	AIR TEMP. ENTERING INDOOR COIL (°F)	ID CFM								
		**625-683			694-759			763-835		
		MBH	COP	KW	MBH	COP	KW	MBH	COP	KW
60	60	23.3	4.88	1.40	23.6	5.12	1.35	23.8	5.39	1.30
	70	22.6	4.19	1.58	22.9	4.37	1.54	23.3	4.57	1.49
	80	21.9	3.64	1.76	22.3	3.79	1.73	22.8	3.94	1.69
47	60	21.9	4.27	1.50	22.2	4.42	1.47	22.5	4.58	1.44
	70	21.0	3.76	1.64	21.4	3.87	1.62	21.8	3.99	1.60
	80	20.0	3.32	1.77	20.6	3.41	1.77	21.2	3.51	1.77
40	60	21.2	2.95	2.11	21.5	3.05	2.06	21.8	3.16	2.02
	70	20.1	2.51	2.35	20.6	2.63	2.30	21.1	2.74	2.25
	80	19.1	2.16	2.59	19.7	2.28	2.53	20.4	2.41	2.48
30	60	19.4	1.91	2.97	20.1	2.23	2.64	20.7	2.64	2.30
	70	18.9	1.65	3.36	19.6	1.94	2.95	20.2	2.34	2.53
	80	18.4	1.43	3.75	19.1	1.72	3.26	19.8	2.10	2.76
17	60	17.1	1.50	3.34	20.6	1.94	3.12	24.2	2.45	2.89
	70	14.8	1.22	3.55	16.7	1.49	3.28	18.6	1.81	3.01
	80	12.5	0.97	3.75	12.8	1.09	3.44	13.1	1.23	3.13
10	60	11.9	0.98	3.54	12.3	1.06	3.38	12.6	1.15	3.21
	70	11.9	0.96	3.64	12.1	1.03	3.46	12.4	1.11	3.27
	80	11.9	0.93	3.75	12.0	1.00	3.54	12.1	1.07	3.32

**NOTE:** ALL CAPACITIES INCLUDE INDOOR FAN HEAT. KW VALUES ARE FOR THE SYSTEM (OUTDOOR + INDOOR).

**NOTE:** \*\*Use the following High/Medium/Low Airflow correlations for different OD DB Temps. 60F (763/694/625CFM); 47F (825/750/675CFM); 40F (835/759/683CFM); 30F (833/757/681CFM); 17F (824/749/674CFM); 10F (810/736/662CFM).

Yellow shaded cells are AHRI High Heating conditions.

Orange shaded cells are AHRI Low Heating conditions.

Multipliers for determining the performance with other indoor sections.

**COIL MULTIPLIERS - 2 TON**

Air Handler	Coil	MBH	COP	KW
AVV25BE12	-	1.00	1.00	1.00
MVC12BN21	CM25BE1A1	1.05	1.00	0.95

**FURNACE MULTIPLIERS - 2 TON**

Furnaces	Coil	T.C.	S.C.	KW
TM9V060B12MP11	CM25BE1A1	1.05	0.96	0.99
TM9V080B12MP11	CM25BE1A1	1.05	0.96	0.99
TP9C060B12MP12	CM25BE1A1	1.05	0.96	0.99
TP9C080B12MP12	CM25BE1A1	1.05	0.96	0.99
CP9C060B12MP12	CM25BE1A1	1.05	0.96	0.99
CP9C080B12MP12	CM25BE1A1	1.05	0.96	0.99

**EXTENDED RANGE HEATING DATA**

CONDENSING UNIT MODEL NO		HC20B2421S								
AIR TEMP. ENTERING OUTDOOR UNIT (°F)	AIR TEMP. ENTERING INDOOR COIL (°F)	ID CFM								
		670			744			818		
		MBH	COP	KW	MBH	COP	KW	MBH	COP	KW
0	60	18.4	1.46	3.68	18.6	1.49	3.66	18.8	1.51	3.64
	70	18.2	1.41	3.77	18.4	1.43	3.76	18.6	1.44	3.76
	80	17.9	1.36	3.86	18.1	1.37	3.87	18.3	1.38	3.89
-5	60	17.9	1.29	4.05	18.1	1.32	4.01	18.3	1.35	3.97
	70	17.5	1.20	4.29	17.9	1.26	4.14	18.2	1.34	3.99
	80	17.1	1.11	4.52	17.7	1.21	4.27	18.2	1.33	4.02

**NOTE:** ALL CAPACITIES INCLUDE INDOOR FAN HEAT. KW VALUES ARE FOR THE SYSTEM (OUTDOOR + INDOOR).

## PERFORMANCE DATA - 3 TON

COOLING PERFORMANCE DATA - HIGH																
AIR CONDITIONER MODEL NO.		HC20B3621S														
AIR TEMP. ENTERING OUTDOOR UNIT (°F)	IDCFM	1020					1200					1320				
	ID DB (°F)	80	80	75	80	80	80	80	75	80	80	80	80	75	80	80
	ID WB (°F)	57	62	62	67	72	57	62	62	67	72	57	62	62	67	72
55	T.C.	32.3	32.7	30.8	32.1	37.1	33.2	32.8	30.7	32.8	38.6	34.0	32.9	30.7	33.6	40.2
	S.C.	31.4	30.1	25.1	24.1	18.2	32.7	30.8	26.3	25.5	18.7	34.0	31.5	27.5	26.9	19.2
	KW	1.07	1.05	1.06	1.24	0.99	1.09	1.10	1.09	1.29	1.05	1.12	1.15	1.12	1.33	1.11
65	T.C.	32.4	32.7	31.3	33.1	37.9	33.4	33.0	31.5	33.9	39.1	34.3	33.3	31.7	34.6	40.2
	S.C.	31.6	30.6	25.2	24.9	18.6	32.9	31.4	26.5	26.4	19.3	34.2	32.1	27.8	27.9	19.9
	KW	1.39	1.38	1.32	1.41	1.26	1.44	1.41	1.37	1.45	1.32	1.48	1.43	1.41	1.50	1.37
75	T.C.	32.5	32.7	31.8	34.1	38.8	33.5	33.2	32.2	34.9	39.5	34.6	33.7	32.7	35.6	40.2
	S.C.	31.8	31.2	25.2	25.8	19.0	33.1	32.0	26.7	27.4	19.9	34.4	32.7	28.1	28.9	20.7
	KW	1.72	1.71	1.59	1.57	1.53	1.78	1.71	1.64	1.62	1.58	1.84	1.71	1.69	1.67	1.63
85	T.C.	32.6	32.8	32.3	35.1	39.7	33.6	33.4	33.0	35.9	40.4	34.6	34.1	33.7	36.6	41.2
	S.C.	32.1	31.7	25.7	26.7	19.4	33.3	32.5	27.1	27.8	20.4	34.5	33.3	28.4	29.0	21.4
	KW	2.12	2.13	2.07	2.06	2.05	2.18	2.16	2.12	2.12	2.11	2.24	2.19	2.17	2.18	2.17
95	T.C.	32.7	32.9	32.7	36.0	40.6	33.7	33.7	33.7	36.9	41.4	34.6	34.5	34.7	37.7	42.1
	S.C.	32.3	32.3	26.2	27.5	19.9	33.4	33.1	27.4	28.3	21.0	34.5	34.0	28.7	29.1	22.1
	KW	2.52	2.54	2.54	2.54	2.57	2.58	2.61	2.60	2.61	2.64	2.65	2.67	2.66	2.68	2.71
105	T.C.	32.8	33.0	33.2	37.0	41.5	33.7	34.0	34.5	37.9	42.3	34.6	35.0	35.7	38.7	43.0
	S.C.	32.6	32.6	26.7	28.4	20.3	33.5	33.6	27.8	28.8	21.6	34.5	34.6	29.0	29.2	22.9
	KW	3.13	3.15	3.16	3.17	3.20	3.20	3.22	3.22	3.24	3.27	3.28	3.29	3.28	3.31	3.35
115	T.C.	32.9	33.1	33.7	38.0	42.4	33.8	34.2	35.2	38.9	43.2	34.6	35.4	36.7	39.7	44.0
	S.C.	32.8	32.9	27.2	29.3	20.7	33.7	34.1	28.2	29.3	22.2	34.5	35.2	29.2	29.2	23.6
	KW	3.73	3.74	3.76	3.78	3.81	3.80	3.81	3.82	3.85	3.89	3.88	3.89	3.89	3.91	3.96
125	T.C.	33.1	33.2	34.2	39.0	43.3	33.8	34.5	36.0	39.9	44.1	34.6	35.8	37.7	40.7	44.9
	S.C.	33.1	33.2	27.7	30.1	21.1	33.8	34.5	28.6	29.7	22.7	34.5	35.8	29.5	29.3	24.4
	KW	4.32	4.33	4.36	4.39	4.42	4.41	4.41	4.43	4.46	4.50	4.49	4.49	4.49	4.52	4.58

NOTE: ALL CAPACITIES INCLUDE INDOOR FAN HEAT. KW VALUES ARE FOR THE SYSTEM (OUTDOOR + INDOOR).

Green shaded cells are ACCA (TVA) conditions.

Blue shaded cells are AHRI conditions.

## Multipliers for determining the performance with other indoor sections.

NOTE: For dry bulb temperatures different than those listed (between 73-87 °F), sensible capacity increases by 1060 BTUH per 1000 CFM per degree above the listed temperature and decreases by 1060 BTUH per 1000 CFM per degree below the listed temperature.

## COIL MULTIPLIERS - 3 TON

Air Handler	Coil	T.C.	S.C.	KW
AVV38CE22	–	1.00	1.00	1.00
MVC16CN21	CM38CE2A1	0.99	1.04	1.02

## FURNACE MULTIPLIERS - 3 TON

Furnaces	Coil	T.C.	S.C.	KW
TM9V080C16MP11	CM38CE2A1	1.03	1.09	1.06
TM9V100C16MP11	CM38CE2A1	1.03	1.09	1.06
TP9C080C16MP12	CM38CE2A1	1.03	1.09	1.06
TP9C100C16MP12	CM38CE2A1	1.03	1.09	1.06
CP9C080C16MP12	CM38CE2A1	1.03	1.09	1.06
CP9C100C16MP12	CM38CE2A1	1.03	1.09	1.06

HEATING PERFORMANCE DATA - HIGH										
CONDENSING UNIT MODEL NO		HC20B3621S								
AIR TEMP. ENTERING OUTDOOR UNIT (°F)	AIR TEMP. ENTERING INDOOR COIL (°F)	ID CFM								
		**990-1035			1100-1150			1210-1265		
		MBH	COP	KW	MBH	COP	KW	MBH	COP	KW
60	60	40.6	6.78	1.75	40.6	6.82	1.74	40.6	6.86	1.73
	70	33.4	4.68	2.09	34.7	4.89	2.08	36.1	5.10	2.07
	80	32.3	3.91	2.42	34.4	4.17	2.42	36.4	4.43	2.41
47	60	36.2	4.41	2.41	36.4	4.48	2.38	36.6	4.56	2.35
	70	35.4	3.86	2.68	35.7	3.95	2.65	36.1	4.03	2.62
	80	34.5	3.42	2.95	35.0	3.51	2.92	35.6	3.61	2.89
40	60	32.8	3.87	2.49	33.6	3.99	2.47	34.5	4.12	2.45
	70	32.6	3.47	2.75	33.0	3.56	2.72	33.4	3.64	2.69
	80	32.3	3.15	3.01	32.4	3.20	2.97	32.4	3.25	2.92
30	60	32.0	3.51	2.67	32.1	3.53	2.66	32.2	3.55	2.66
	70	31.4	2.98	3.08	31.9	3.04	3.08	32.4	3.09	3.08
	80	30.8	2.58	3.50	31.7	2.66	3.49	32.7	2.74	3.49
17	60	29.7	2.43	3.58	31.4	2.57	3.57	33.0	2.72	3.56
	70	31.3	2.30	3.98	31.8	2.45	3.80	32.4	2.62	3.62
	80	28.8	1.92	4.38	30.3	2.20	4.03	31.9	2.53	3.69
10	60	29.1	2.10	4.07	29.1	2.10	4.06	29.13	2.11	4.04
	70	27.0	1.77	4.46	27.7	1.92	4.23	28.4	2.08	3.99
	80	24.9	1.50	4.85	26.8	1.78	4.40	28.6	2.12	3.95

**NOTE:** ALL CAPACITIES INCLUDE INDOOR FAN HEAT. KW VALUES ARE FOR THE SYSTEM (OUTDOOR + INDOOR).

**NOTE:** \*\*Use the following High/Medium/Low Airflow correlations for different OD DB Temps. 60F, 17F & 10F (1265/1150/1035CFM); 47F & 40F (1210/1100/990CFM); 30F (1238/1125/1013CFM).

Yellow shaded cells are AHRI High Heating conditions.

Orange shaded cells are AHRI Low Heating conditions.

Multipliers for determining the performance with other indoor sections.

#### COIL MULTIPLIERS - 3 TON

Air Handler	Coil	MBH	COP	KW
AVV38CE22	-	1.00	1.00	1.00
MVC16CN21	CM38CE2A1	1.05	0.99	0.96

#### FURNACE MULTIPLIERS - 3 TON

Furnaces	Coil	T.C.	S.C.	KW
TM9V080C16MP11	CM38CE2A1	1.05	0.97	0.98
TM9V100C16MP11	CM38CE2A1	1.05	0.97	0.98
TP9C080C16MP12	CM38CE2A1	1.05	0.97	0.98
TP9C100C16MP12	CM38CE2A1	1.05	0.97	0.98
CP9C080C16MP12	CM38CE2A1	1.05	0.97	0.98
CP9C100C16MP12	CM38CE2A1	1.05	0.97	0.98

#### EXTENDED RANGE HEATING DATA

CONDENSING UNIT MODEL NO		HC20B3621S								
AIR TEMP. ENTERING OUTDOOR UNIT (°F)	AIR TEMP. ENTERING INDOOR COIL (°F)	ID CFM								
		945			1050			1155		
		MBH	COP	KW	MBH	COP	KW	MBH	COP	KW
0	60	27.3	1.99	4.01	28.2	2.00	4.12	29.1	2.01	4.23
	70	27.1	1.70	4.66	27.8	1.76	4.62	28.5	1.82	4.58
	80	27.0	1.49	5.32	27.4	1.57	5.13	27.9	1.66	4.93
-5	60	24.2	1.78	3.98	25.6	1.88	3.99	27.1	1.99	3.99
	70	24.1	1.61	4.39	25.3	1.70	4.36	26.5	1.79	4.34
	80	24.0	1.46	4.80	25.0	1.54	4.74	26.0	1.63	4.68

**NOTE:** ALL CAPACITIES INCLUDE INDOOR FAN HEAT. KW VALUES ARE FOR THE SYSTEM (OUTDOOR + INDOOR).

## PERFORMANCE DATA - 4 TON

COOLING PERFORMANCE DATA - HIGH																
AIR CONDITIONER MODEL NO.		HC20B4821S														
AIR TEMP. ENTERING OUTDOOR UNIT (°F)	IDCFM	1360					1560					1760				
	ID DB (°F)	80	80	75	80	80	80	80	75	80	80	80	80	75	80	80
	ID WB (°F)	57	62	62	67	72	57	62	62	67	72	57	62	62	67	72
55	T.C.	41.5	42.6	42.6	46.6	51.7	43.1	43.4	43.1	47.0	51.9	44.6	44.3	43.7	47.5	52.1
	S.C.	25.6	38.7	32.6	32.2	24.9	26.5	41.2	34.3	33.6	25.1	27.4	43.6	36.1	35.0	25.4
	KW	1.68	1.66	1.66	1.58	1.56	1.76	1.75	1.77	1.68	1.67	1.85	1.85	1.87	1.79	1.77
65	T.C.	41.6	42.6	42.7	46.7	51.8	43.2	43.5	43.2	47.2	52.1	44.7	44.5	43.8	47.7	52.4
	S.C.	33.6	38.9	32.8	32.4	25.4	34.8	41.4	34.7	34.1	26.0	36.1	44.0	36.6	35.7	26.6
	KW	2.03	2.02	2.03	1.98	1.96	2.13	2.12	2.14	2.09	2.07	2.22	2.22	2.24	2.19	2.18
75	T.C.	41.7	42.6	42.7	46.8	51.9	43.3	43.6	43.3	47.4	52.3	44.8	44.6	43.9	48.0	52.7
	S.C.	41.6	39.2	33.0	32.6	26.0	43.1	41.7	35.0	34.6	26.9	44.7	44.3	37.0	36.5	27.8
	KW	2.38	2.39	2.39	2.38	2.36	2.49	2.49	2.50	2.49	2.48	2.60	2.59	2.62	2.59	2.59
85	T.C.	41.8	42.7	42.7	47.0	51.9	43.4	43.8	43.3	47.6	52.5	45.0	44.8	44.0	48.2	53.1
	S.C.	41.6	39.4	33.1	32.9	26.6	43.2	42.0	35.3	35.0	27.2	44.8	44.7	37.5	37.2	27.9
	KW	2.95	2.95	2.96	2.97	2.97	3.06	3.07	3.08	3.09	3.09	3.18	3.18	3.20	3.21	3.21
95	T.C.	41.9	42.7	42.8	47.1	52.0	43.5	43.9	43.4	47.8	52.7	45.1	45.0	44.1	48.5	53.4
	S.C.	41.7	39.6	33.3	33.1	27.1	43.3	42.3	35.7	35.5	27.6	44.9	45.0	38.0	38.0	28.1
	KW	3.51	3.52	3.53	3.56	3.58	3.64	3.65	3.66	3.69	3.71	3.76	3.78	3.79	3.82	3.83
105	T.C.	42.5	43.7	43.7	48.3	53.6	44.1	44.8	44.4	49.0	54.1	45.8	45.8	45.1	49.7	54.7
	S.C.	42.3	40.1	33.5	33.3	26.4	44.0	42.9	35.7	35.5	27.7	45.8	45.8	37.9	37.8	29.0
	KW	4.47	4.49	4.50	4.54	4.60	4.61	4.63	4.63	4.68	4.74	4.74	4.76	4.77	4.81	4.88
115	T.C.	40.9	42.1	41.0	45.2	52.8	42.8	42.9	41.9	47.5	53.5	44.7	43.6	42.9	49.8	54.2
	S.C.	40.7	38.4	32.4	32.2	25.3	42.7	40.9	34.1	34.5	27.1	44.7	43.4	35.9	36.7	28.9
	KW	5.75	5.77	5.50	5.85	5.52	5.76	5.87	5.73	5.86	5.70	5.76	5.97	5.96	5.87	5.89
125	T.C.	38.3	38.4	38.2	42.2	46.7	39.5	39.6	38.6	42.7	47.1	40.7	40.9	39.1	43.1	47.5
	S.C.	37.9	37.7	31.2	31.2	24.2	39.2	39.2	33.3	33.4	25.4	40.4	40.8	35.3	35.5	26.6
	KW	5.78	5.78	5.39	5.47	5.51	5.79	5.88	5.52	5.59	5.65	5.79	5.97	5.64	5.71	5.79

NOTE: ALL CAPACITIES INCLUDE INDOOR FAN HEAT. KW VALUES ARE FOR THE SYSTEM (OUTDOOR + INDOOR).

Green shaded cells are ACCA (TVA) conditions.

Blue shaded cells are AHRI conditions.

## Multipliers for determining the performance with other indoor sections.

NOTE: For dry bulb temperatures different than those listed (between 73-87 °F), sensible capacity increases by 1060 BTUH per 1000 CFM per degree above the listed temperature and decreases by 1060 BTUH per 1000 CFM per degree below the listed temperature.

## COIL MULTIPLIERS - 4 TON

Air Handler	Coil	T.C.	S.C.	KW
AVV50CE32	-	1.00	1.04	1.05
AVV50DE32	-	1.00	1.00	1.00
MVC16CN21	CM50CE3A1	1.00	1.04	1.05
MVC20DN21	CM50DE3A1	1.00	1.05	1.05



HEATING PERFORMANCE DATA - HIGH										
CONDENSING UNIT MODEL NO		HC20B4821S								
AIR TEMP. ENTERING OUTDOOR UNIT (°F)	AIR TEMP. ENTERING INDOOR COIL (°F)	ID CFM								
		1395			1550			1705		
		MBH	COP	KW	MBH	COP	KW	MBH	COP	KW
60	60	57.4	6.17	2.73	57.4	6.18	2.72	57.4	6.18	2.72
	70	56.3	5.39	3.06	56.6	5.39	3.08	56.8	5.39	3.09
	80	55.2	4.66	3.47	55.7	4.72	3.46	56.3	4.77	3.46
47	60	50.2	4.22	3.48	50.5	4.26	3.48	50.9	4.29	3.47
	70	49.4	3.70	3.90	49.7	3.74	3.90	50.1	3.77	3.89
	80	48.6	3.29	4.33	49.0	3.32	4.32	49.3	3.35	4.31
40	60	46.3	3.73	3.64	47.1	3.81	3.61	47.9	3.90	3.59
	70	45.6	3.28	4.07	46.2	3.35	4.04	46.7	3.42	4.01
	80	45.0	2.93	4.50	45.3	2.97	4.46	45.6	3.02	4.42
30	60	41.7	2.87	4.26	42.9	3.03	4.15	44.1	3.20	4.04
	70	41.0	2.52	4.76	42.0	2.64	4.66	43.0	2.76	4.56
	80	40.3	2.24	5.26	41.1	2.33	5.17	41.9	2.42	5.08
17	60	39.9	2.58	4.54	41.9	2.70	4.54	43.9	2.83	4.54
	70	35.5	2.02	5.14	36.8	2.08	5.19	38.1	2.14	5.23
	80	31.0	1.58	5.74	31.7	1.71	5.41	32.4	1.87	5.09
10	60	37.3	2.11	5.18	37.3	2.15	5.08	37.3	2.19	4.99
	70	34.2	1.88	5.31	34.5	1.89	5.36	34.9	1.89	5.41
	80	31.0	1.51	6.00	31.7	1.57	5.92	32.4	1.63	5.84

**NOTE:** ALL CAPACITIES INCLUDE INDOOR FAN HEAT. KW VALUES ARE FOR THE SYSTEM (OUTDOOR + INDOOR).

Yellow shaded cells are AHRI High Heating conditions.

Orange shaded cells are AHRI Low Heating conditions.

**Multipliers for determining the performance with other indoor sections.**

#### COIL MULTIPLIERS - 4 TON

Air Handler	Coil	MBH	COP	KW
AVV50CE32	–	1.05	0.99	0.96
AVV50DE32	–	1.00	1.00	1.00
MVC16CN21	CM50CE3A1	1.05	0.99	0.96
MVC20DN21	CM50DE3A1	1.05	1.00	0.95

EXTENDED RANGE HEATING DATA										
CONDENSING UNIT MODEL NO		HC20B4821S								
AIR TEMP. ENTERING OUTDOOR UNIT (°F)	AIR TEMP. ENTERING INDOOR COIL (°F)	ID CFM								
		1395			1550			1705		
		MBH	COP	KW	MBH	COP	KW	MBH	COP	KW
0	60	35.0	2.06	4.98	35.3	2.12	4.89	35.7	2.18	4.80
	70	33.0	1.76	5.50	33.5	1.82	5.40	34.0	1.88	5.31
	80	31.0	1.51	6.01	31.6	1.57	5.91	32.3	1.63	5.82
-5	60	30.2	2.01	4.39	31.0	1.96	4.63	31.8	1.92	4.86
	70	29.6	1.73	5.00	30.6	1.74	5.13	31.6	1.76	5.27
	80	29.0	1.51	5.61	30.2	1.57	5.64	31.4	1.62	5.68

**NOTE:** ALL CAPACITIES INCLUDE INDOOR FAN HEAT. KW VALUES ARE FOR THE SYSTEM (OUTDOOR + INDOOR).

<b>COOLING PERFORMANCE DATA - HIGH</b>																
<b>AIR CONDITIONER MODEL NO.</b>		<b>HC20B6021S</b>														
<b>AIR TEMP. ENTERING OUTDOOR UNIT (°F)</b>	<b>IDCFM</b>	<b>1530</b>					<b>1800</b>					<b>1980</b>				
	<b>ID DB (°F)</b>	<b>80</b>	<b>80</b>	<b>75</b>	<b>80</b>	<b>80</b>	<b>80</b>	<b>80</b>	<b>75</b>	<b>80</b>	<b>80</b>	<b>80</b>	<b>80</b>	<b>75</b>	<b>80</b>	<b>80</b>
	<b>ID WB (°F)</b>	<b>57</b>	<b>62</b>	<b>62</b>	<b>67</b>	<b>72</b>	<b>57</b>	<b>62</b>	<b>62</b>	<b>67</b>	<b>72</b>	<b>57</b>	<b>62</b>	<b>62</b>	<b>67</b>	<b>72</b>
<b>55</b>	<b>T.C.</b>	48.8	50.9	51.8	52.5	56.4	50.0	51.6	52.2	52.9	56.8	51.2	52.4	52.6	53.3	57.2
	<b>S.C.</b>	48.7	45.0	37.0	36.9	27.0	49.5	47.5	38.9	37.3	27.02	50.2	49.9	40.7	37.7	27.0
	<b>KW</b>	2.21	2.19	2.21	2.19	2.16	2.37	2.37	2.40	2.37	2.34	2.54	2.56	2.59	2.54	2.52
<b>65</b>	<b>T.C.</b>	48.8	50.9	51.8	52.6	57.8	50.0	51.7	52.2	53.3	57.8	51.3	52.6	52.6	54.0	57.8
	<b>S.C.</b>	48.7	45.0	37.1	37.3	28.2	49.5	47.5	39.1	38.2	28.9	50.2	50.1	41.1	39.1	29.7
	<b>KW</b>	2.84	2.86	2.85	2.83	2.83	2.93	3.02	3.04	3.03	3.02	3.02	3.19	3.23	3.22	3.22
<b>75</b>	<b>T.C.</b>	48.8	50.9	51.8	52.7	59.2	50.1	51.8	52.2	53.7	58.8	51.3	52.8	52.6	54.8	58.5
	<b>S.C.</b>	48.7	45.0	37.2	37.7	29.3	49.5	47.6	39.3	39.1	30.9	50.2	50.2	41.5	40.4	32.4
	<b>KW</b>	3.47	3.53	3.50	3.48	3.50	3.48	3.67	3.68	3.69	3.71	3.50	3.82	3.87	3.90	3.91
<b>85</b>	<b>T.C.</b>	49.8	51.3	51.9	52.7	59.2	50.5	52.1	52.3	54.1	59.2	51.3	53.0	52.7	55.5	59.1
	<b>S.C.</b>	48.8	45.4	37.3	37.7	29.3	49.5	47.9	39.5	39.1	32.2	50.2	50.4	41.8	40.5	35.0
	<b>KW</b>	4.07	4.11	4.09	4.11	4.13	4.18	4.28	4.29	4.31	4.33	4.29	4.46	4.49	4.51	4.53
<b>95</b>	<b>T.C.</b>	50.7	51.7	51.9	52.7	59.2	51.0	52.5	52.3	54.5	59.5	51.3	53.2	52.7	56.3	59.8
	<b>S.C.</b>	48.8	45.8	37.3	37.7	29.3	49.5	48.1	39.8	39.1	33.5	50.2	50.5	42.2	40.5	37.7
	<b>KW</b>	4.67	4.69	4.69	4.74	4.76	4.88	4.89	4.90	4.93	4.95	5.08	5.10	5.10	5.12	5.14
<b>105</b>	<b>T.C.</b>	46.7	49.7	51.9	52.7	59.2	48.9	50.5	52.0	53.9	60.2	51.1	51.2	52.1	55.2	61.2
	<b>S.C.</b>	46.0	45.2	37.3	37.0	27.3	48.1	47.7	39.8	38.8	29.7	50.2	50.3	42.2	40.5	32.1
	<b>KW</b>	5.19	5.26	5.27	5.34	5.42	5.41	5.45	5.48	5.55	5.63	5.63	5.64	5.70	5.75	5.83
<b>115</b>	<b>T.C.</b>	46.7	46.1	46.1	51.0	56.0	47.4	46.9	46.7	51.5	56.8	48.0	47.7	47.4	51.9	57.6
	<b>S.C.</b>	42.4	42.4	35.4	35.3	27.2	44.7	45.0	37.8	37.4	28.8	46.9	47.6	40.2	39.6	30.4
	<b>KW</b>	5.66	5.82	5.82	5.91	6.01	5.83	5.98	5.99	6.07	6.17	6.01	6.14	6.15	6.24	6.33
<b>125</b>	<b>T.C.</b>	41.2	43.1	43.2	46.7	52.6	42.8	44.1	44.2	47.8	53.3	44.4	45.0	45.1	49.0	54.1
	<b>S.C.</b>	41.2	39.0	32.5	32.2	25.8	42.7	41.7	34.7	34.6	27.0	44.3	44.4	36.9	37.0	28.2
	<b>KW</b>	6.14	6.21	6.18	6.24	6.43	6.30	6.35	6.33	6.42	6.56	6.47	6.50	6.48	6.60	6.69

**NOTE:** ALL CAPACITIES INCLUDE INDOOR FAN HEAT. KW VALUES ARE FOR THE SYSTEM (OUTDOOR + INDOOR).

Green shaded cells are ACCA (TVA) conditions.

Blue shaded cells are AHRI conditions.

#### Multipliers for determining the performance with other indoor sections.

**NOTE:** For dry bulb temperatures different than those listed (between 73-87 °F), sensible capacity increases by 1060 BTUH per 1000 CFM per degree above the listed temperature and decreases by 1060 BTUH per 1000 CFM per degree below the listed temperature.

#### COIL MULTIPLIERS - 5 TON

<b>Air Handler</b>	<b>Coil</b>	<b>T.C.</b>	<b>S.C.</b>	<b>KW</b>
AVV61CE42	–	1.00	0.98	1.03
AVV61DE42	–	1.00	1.00	1.00
MVC20DN21	CM61DE4A1	0.99	0.99	1.02

HEATING PERFORMANCE DATA - HIGH										
CONDENSING UNIT MODEL NO		HC20B6021S								
AIR TEMP. ENTERING OUTDOOR UNIT (°F)	AIR TEMP. ENTERING INDOOR COIL (°F)	ID CFM								
		**1372-1580			1524-1755			1676-1930		
		MBH	COP	KW	MBH	COP	KW	MBH	COP	KW
60	60	59.2	4.64	3.73	60.2	4.73	3.73	61.1	4.82	3.72
	70	57.7	4.13	4.10	58.8	4.21	4.09	59.9	4.30	4.09
	80	56.2	3.69	4.46	57.5	3.78	4.46	58.7	3.86	4.46
47	60	56.5	4.31	3.84	58.1	4.43	3.84	59.6	4.55	3.84
	70	54.1	3.75	4.23	55.3	3.83	4.23	56.4	3.91	4.23
	80	51.6	3.27	4.62	52.4	3.33	4.62	53.3	3.38	4.62
40	60	55.1	3.46	4.67	56.9	3.58	4.67	58.8	3.69	4.66
	70	47.2	2.89	4.79	50.9	3.15	4.74	54.6	3.41	4.68
	80	39.4	2.35	4.91	44.9	2.73	4.81	50.4	3.13	4.71
30	60	50.6	3.17	4.68	51.9	3.25	4.68	53.2	3.34	4.67
	70	40.4	2.52	4.70	41.9	2.62	4.70	43.5	2.71	4.70
	80	30.2	1.87	4.72	32.0	1.98	4.72	33.8	2.10	4.72
17	60	47.5	2.63	5.30	47.5	2.76	5.05	47.5	2.90	4.80
	70	38.8	2.13	5.34	39.0	2.20	5.20	39.2	2.27	5.07
	80	30.2	1.64	5.38	30.5	1.67	5.36	30.9	1.70	5.34
10	60	43.5	2.26	5.64	44.0	2.35	5.49	44.43	2.44	5.34
	70	36.8	1.85	5.84	36.9	1.87	5.76	36.9	1.90	5.69
	80	30.2	1.46	6.04	29.8	1.44	6.04	29.3	1.42	6.04

**NOTE:** ALL CAPACITIES INCLUDE INDOOR FAN HEAT. KW VALUES ARE FOR THE SYSTEM (OUTDOOR + INDOOR).

**NOTE:** \*\*Use the following High/Medium/Low Airflow correlations for different OD DB Temps. 60F (1690/1536/1382CFM); 47F (1676/1524/1372CFM); 40F (1895/1723/1551CFM); 30F (1905/1732/1559CFM); 17F (1923/1748/1573CFM); 10F (1931/1755/1580CFM)

Yellow shaded cells are AHRI High Heating conditions.

Orange shaded cells are AHRI Low Heating conditions.

Multipliers for determining the performance with other indoor sections.

#### COIL MULTIPLIERS - 5 TON

Air Handler	Coil	MBH	COP	KW
AVV61CE42	-	1.06	1.01	0.94
AVV61DE42	-	1.00	1.00	1.00
MVC20DN21	CM61DE4A1	1.06	0.97	0.97

EXTENDED RANGE HEATING DATA										
CONDENSING UNIT MODEL NO		HC20B6021S								
AIR TEMP. ENTERING OUTDOOR UNIT (°F)	AIR TEMP. ENTERING INDOOR COIL (°F)	ID CFM								
		844-1133			938-1259			1032-1385		
		MBH	COP	KW	MBH	COP	KW	MBH	COP	KW
0	60	36.0	1.84	5.72	39.3	2.06	5.59	42.6	2.28	5.46
	70	32.3	1.64	5.76	33.9	1.76	5.65	35.6	1.88	5.54
	80	28.6	1.44	5.80	28.6	1.47	5.71	28.7	1.49	5.63
-5	60	28.1	1.40	5.88	31.2	1.56	5.86	34.4	1.72	5.84
	70	28.0	1.39	5.93	30.1	1.50	5.89	32.2	1.61	5.86
	80	28.0	1.37	5.97	29.0	1.44	5.92	30.1	1.50	5.87

**NOTE:** ALL CAPACITIES INCLUDE INDOOR FAN HEAT. KW VALUES ARE FOR THE SYSTEM (OUTDOOR + INDOOR).

# NOTES