

SHARP SERVICE MANUAL

S7606R21LTFP/

LIGHT DUTY COMMERCIAL MICROWAVE OVEN

MODELS R-21LTF R-21LVF

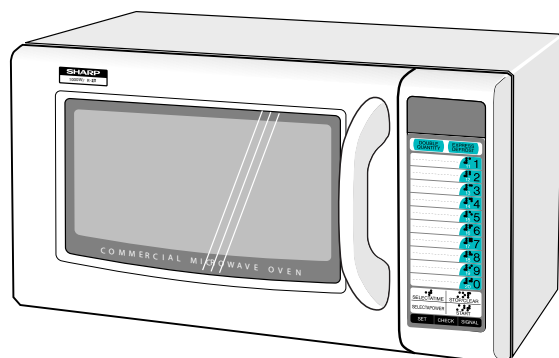

In the interest of user-safety the oven should be restored to its original condition and only parts identical to those specified should be used. **WARNING TO SERVICE PERSONNEL:** Microwave ovens contain circuitry capable of producing very high voltage and current, contact with following parts may result in a severe, possibly fatal, electrical shock. (High Voltage Capacitor, High Voltage Power Transformer, Magnetron, High Voltage Rectifier Assembly, High Voltage Harness etc..)

CONTENTS

PRECAUTIONS TO BE OBSERVED BEFORE AND DURING SERVICING TO AVOID POSSIBLE EXPOSURE TO EXCESSIVE MICROWAVE ENERGY

BEFORE SERVICING

CHAPTER 1. WARNING TO SERVICE PERSONNEL

CHAPTER 2. MICROWAVE MEASUREMENT PROCEDURE

CHAPTER 3. FOREWORD AND WARNING

CHAPTER 4. PRODUCT DESCRIPTION

CHAPTER 5. GENERAL INFORMATION

CHAPTER 6. OPERATION

CHAPTER 7. TROUBLESHOOTING GUIDE

CHAPTER 8. TEST PROCEDURES

CHAPTER 9. TOUCH CONTROL PANEL ASSEMBLY

CHAPTER 10. PRECAUTIONS FOR USING LEAD-FREE SOLDER

CHAPTER 11. COMPONENT REPLACEMENT AND ADJUSTMENT PROCEDURE

CHAPTER 12. CIRCUIT DIAGRAMS

Parts List

SHARP CORPORATION

This document has been published to be used for after sales service only.
The contents are subject to change without notice.

CONTENTS

PRECAUTIONS TO BE OBSERVED BEFORE AND DURING SERVICING TO AVOID POSSIBLE EXPOSURE TO EXCESSIVE MICROWAVE ENERGY

CHAPTER 1. WARNING TO SERVICE PERSONNEL

- [1] Before Servicing 1-1
- [2] When the testing is completed, 1-1
- [3] After repairing 1-1

CHAPTER 2. MICROWAVE MEASUREMENT PROCEDURE

- [1] Requirements: 2-1
- [2] Preparation for testing: 2-1
- [3] Leakage test: 2-1

CHAPTER 3. FOREWORD AND WARNING

- [1] FOREWORD 3-1
- [2] WARNING 3-1
- [3] DANGER 3-1

CHAPTER 4. PRODUCT DESCRIPTION

- [1] SPECIFICATIONS 4-1

CHAPTER 5. GENERAL INFORMATION

- [1] GROUNDING INSTRUCTIONS 5-1
- [2] OVEN DIAGRAM 5-1

CHAPTER 6. OPERATION

- [1] DESCRIPTION OF OPERATING SEQUENCE 6-1
- [2] OVEN SCHEMATIC 6-2
- [3] DESCRIPTION AND FUNCTION OF COMPONENTS 6-3

CHAPTER 7. TROUBLESHOOTING GUIDE

- [1] TROUBLESHOOTING CHART 7-1

CHAPTER 8. TEST PROCEDURES

- [1] Procedure A: MAGNETRON ASSEMBLY TEST 8-1
- [2] Procedure B: POWER TRANSFORMER TEST 8-1
- [3] Procedure C: HIGH VOLTAGE RECTIFIER TEST 8-1
- [4] Procedure D: HIGH VOLTAGE CAPACITOR TEST 8-2
- [5] Procedure E: THERMAL CUT OUT TEST.. 8-2
- [6] Procedure F: SECONDARY INTERLOCK SWITCH TEST 8-2
- [7] Procedure F: PRIMARY INTERLOCK SYSTEM TEST 8-3
- [8] Procedure G: MONITOR SWITCH TEST... 8-3
- [9] Procedure H: BLOWN MINITOR FUSE TEST 8-3
- [10] Procedure I: NOISE FILTER TEST..... 8-4
- [11] Procedure J: TOUCH CONTROL PANEL ASSEMBLY TEST 8-4
- [12] Procedure K: KEY UNIT TEST 8-5
- [13] Procedure L: RELAY TEST 8-6

- [14] Procedure M: FOIL PATTERN ON THE PRINTED WIRING BOARD TEST 8-6

CHAPTER 9. TOUCH CONTROL PANEL ASSEMBLY

- [1] OUTLINE OF TOUCH CONTROL PANEL. 9-1
- [2] SERVICING FOR TOUCH CONTROL PANEL 9-1
- [3] PROCEDURE FOR CHECKING/CLEARING SERVICE COUNTS OF MICROWAVE OVEN 9-2
- [4] OTHER SETTING AND CHECKING PROCEDURE 9-3

CHAPTER 10. PRECAUTIONS FOR USING LEAD-FREE SOLDER

- [1] Employing lead-free solder 10-1
- [2] Using lead-free wire solder 10-1
- [3] Soldering 10-1

CHAPTER 11. COMPONENT REPLACEMENT AND ADJUSTMENT PROCEDURE

- [1] WARNING 11-1
- [2] OUTER CASE REMOVAL 11-1
- [3] POWER TRANSFORMER REMOVAL 11-2
- [4] HIGH VOLTAGE RECTIFIER ASSEMBLY AND HIGH VOLTAGE CAPACITOR REMOVAL 11-2
- [5] MAGNETRON REMOVAL 11-2
- [6] CONTROL PANEL ASSEMBLY REMOVAL 11-2
- [7] OVEN LAMP AND LAMP SOCKET REMOVAL 11-3
- [8] POSITIVE LOCK CONNECTOR (NO-CASE TYPE) REMOVAL 11-3
- [9] ANTENNA MOTOR REMOVAL 11-3
- [10] COOLING FAN MOTOR REMOVAL 11-3
- [11] POWER SUPPLY CORD REPLACEMENT 11-4
- [12] DOOR SENSING SWITCH/SECONDARY INTERLOCK SWITCH AND MONITOR SWITCH REMOVAL 11-4
- [13] DOOR SENSING SWITCH/SECONDARY INTERLOCK SWITCH AND MONITOR SWITCH ADJUSTMENT 11-5
- [14] DOOR PARTS REMOVAL 11-5
- [15] ANTENNA MOTOR SHAFT REPLACEMENT 11-6
- [16] INSTALLATION OF CERAMIC SHELF 11-8

CHAPTER 12. CIRCUIT DIAGRAMS

- [1] Pictorial Diagram (Figure S-1) 12-1
- [2] Control Panel Circuit (Figure S-2a and S-2b) 12-2
- [3] Printed Wiring Board (Figure S-3) 12-4

Parts List

PRECAUTIONS TO BE OBSERVED BEFORE AND DURING SERVICING TO AVOID POSSIBLE EXPOSURE TO EXCESSIVE MICROWAVE ENERGY

PRECAUTIONS TO BE OBSERVED BEFORE AND DURING SERVICING TO AVOID POSSIBLE EXPOSURE TO EXCESSIVE MICROWAVE ENERGY

- (a) Do not operate or allow the oven to be operated with the door open.
- (b) Make the following safety checks on all ovens to be serviced before activating the magnetron or other microwave source, and make repairs as necessary: (1) interlock operation, (2) proper door closing, (3) seal and sealing surfaces (arcing, wear, and other damage), (4) damage to or loosening of hinges and latches, (5) evidence of dropping or abuse.
- (c) Before turning on microwave power for any service test or inspection within the microwave generating compartments, check the magnetron, wave guide or transmission line, and cavity for proper alignment, integrity, and connections.
- (d) Any defective or misadjusted components in the interlock, monitor, door seal, and microwave generation and transmission systems shall be repaired, replaced, or adjusted by procedures described in this manual before the oven is released to the owner
- (e) A microwave leakage check to verify compliance with the Federal Performance Standard should be performed on each oven prior to release to the owner.

BEFOR SERVICING

BEFORE SERVICING

Before servicing an operative unit, perform a microwave emission check as per the Microwave Measurement Procedure outlined in this service manual.

If microwave emissions level is in excess of the specified limit, contact SHARP ELECTRONICS CORPORATION immediately @1-800-237-4277.

If the unit operates with the door open, service person should 1) tell the user not to operate the oven and 2) contact SHARP ELECTRONICS CORPORATION and Food and Drug Administration's Center for Devices and Radiological Health immediately.

Service personnel should inform SHARP ELECTRONICS CORPORATION of any certified unit found with emissions in excess of $4\text{mW}/\text{cm}^2$. The owner of the unit should be instructed not to use the unit until the oven has been brought into compliance.

CHAPTER 1. WARNING TO SERVICE PERSONNEL

Microwave ovens contain circuitry capable of producing very high voltage and current, contact with following parts may result in a severe, possibly fatal, electrical shock.

(Example)

High Voltage Capacitor, High Voltage Power Transformer, Magnetron, High Voltage Rectifier Assembly, High Voltage Harness etc..

Read the Service Manual carefully and follow all instructions.

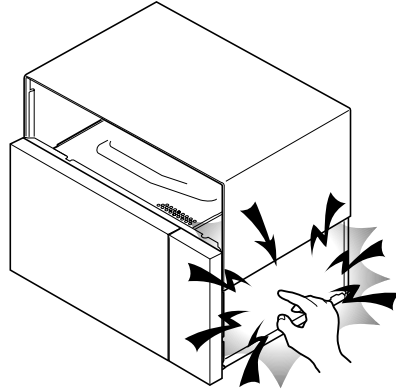

**Don't Touch !
Danger High Voltage**

[1] Before Servicing

1. Disconnect the power supply cord , and then remove outer case.
2. Open the door and block it open.
3. Discharge high voltage capacitor.

WARNING: RISK OF ELECTRIC SHOCK. DISCHARGE THE HIGH-VOLTAGE CAPACITOR BEFORE SERVICING.

The high-voltage capacitor remains charged about 60 seconds after the oven has been switched off. Wait for 60 seconds and then short-circuit the connection of the high-voltage capacitor (that is the connecting lead of the high-voltage rectifier) against the chassis with the use of an insulated screwdriver.

Whenever troubleshooting is performed the power supply must be disconnected. It may, in some cases, be necessary to connect the power supply after the outer case has been removed, in this event,

- 1) Disconnect the power supply cord, and then remove outer case.
- 2) Open the door and block it open.
- 3) Discharge high voltage capacitor.
- 4) Disconnect the leads to the primary of the power transformer.
- 5) Ensure that the leads remain isolated from other components and oven chassis by using insulation tape.
- 6) After that procedure, reconnect the power supply cord.

[2] When the testing is completed,

1. Disconnect the power supply cord, and then remove outer case.
2. Open the door and block it open.
3. Discharge high voltage capacitor.
4. Reconnect the leads to the primary of the power transformer.
5. Reinstall the outer case (cabinet).
6. Reconnect the power supply cord after the outer case is installed.
7. Run the oven and check all functions.

[3] After repairing

1. Reconnect all leads removed from components during testing.
2. Reinstall the outer case (cabinet).
3. Reconnect the power supply cord after the outer case is installed.
4. Run the oven and check all functions.

Microwave ovens should not be run empty. To test for the presence of microwave energy within a cavity, place a cup of cold water on the oven turntable, close the door and set the power to HIGH and set the microwave timer for two (2) minutes. When the two minutes has elapsed (timer at zero) carefully check that the water is now hot. If the water remains cold carry out **Before Servicing** procedure and re-examine the connections to the component being tested.

When all service work is completed and the oven is fully assembled, the microwave power output should be checked and microwave leakage test should be carried out.

CHAPTER 2. MICROWAVE MEASUREMENT PROCEDURE

[1] Requirements:

1. Microwave leakage limit (Power density limit): The power density of microwave radiation emitted by a microwave oven should not exceed 1mW/cm² at any point 5cm or more from the external surface of the oven, measured prior to acquisition by a purchaser, and thereafter (through the useful life of the oven), 5 mW/cm² at any point 5cm or more from the external surface of the oven.
2. Safety interlock switches: Primary interlock relay and door sensing switch shall prevent microwave radiation emission in excess of the requirement as above mentioned, secondary interlock switch shall prevent microwave radiation emission in excess of 5 mW/cm² at any point 5cm or more from the external surface of the oven.

[2] Preparation for testing:

Before beginning the actual measurement of leakage, proceed as follows:

1. Make sure that the actual instrument is operating normally as specified in its instruction booklet.

Important:

Survey instruments that comply with the requirement for instrumentation as prescribed by the performance standard for microwave ovens, 21 CFR 1030.10(c)(3)(i), must be used for testing.

2. Place the oven tray in the oven cavity.
3. Place the load of 275±5 ml (9.8 oz) of tap water initially at 20±5°C (68°F) in the center of the oven cavity.

The water container shall be a low form of 600 ml (20 oz) beaker with an inside diameter of approx. 8.5 cm (3-1/2 in.) and made of an electrically nonconductive material such as glass or plastic.

The placing of this standard load in the oven is important not only to protect the oven, but also to insure that any leakage is measured accurately.

4. Set the cooking control on Full Power Cooking Mode
5. Close the door and select a cook cycle of several minutes. If the water begins to boil before the survey is completed, replace it with 275 ml of cool water.

[3] Leakage test:

Closed-door leakage test (microwave measurement)

1. Grasp the probe of the survey instrument and hold it perpendicular to the gap between the door and the body of the oven.
2. Move the probe slowly, not faster than 1 in./sec. (2.5 cm/sec.) along the gap, watching for the maximum indication on the meter.
3. Check for leakage at the door screen, sheet metal seams and other accessible positions where the continuity of the metal has been breached (eg., around the switches, indicator, and vents).

While testing for leakage around the door pull the door away from the front of the oven as far as is permitted by the closed latch assembly.

4. Measure carefully at the point of highest leakage and make sure that the highest leakage is no greater than 4mW/cm², and that the secondary interlock switch and the primary interlock relay do turn the oven OFF before any door movement.

NOTE: After servicing, record data on service invoice and microwave leakage report.

CHAPTER 3. FOREWORD AND WARNING

[1] FOREWORD

This Manual has been prepared to provide Sharp Electronics Corp. Service Personnel with Operation and Service Information for the SHARP MICROWAVE OVEN, R-21LTF and R-21LVF.

It is recommended that service personnel carefully study the entire text of this manual so that they will be qualified to render satisfactory customer service.

Check the interlock switches and the door seal carefully. Special attention should be given to avoid electrical shock and microwave radiation hazard.

[2] WARNING

Never operate the oven until the following points are ensured.

- (A) The door is tightly closed.
- (B) The door brackets and hinges are not defective.
- (C) The door packing is not damaged.
- (D) The door is not deformed or warped.
- (E) There is not any other visible damage with the oven.

Servicing and repair work must be carried out only by trained service personnel.

[3] DANGER

Certain initial parts are intentionally not grounded and present a risk of electrical shock only during servicing. Service personnel - Do not contact the following parts while the appliance is energized;

High Voltage Capacitor, Power Transformer, Magnetron, High Voltage Rectifier Assembly, High Voltage Harness;

If provided, Vent Hood, Fan assembly, Cooling Fan Motor.

All the parts marked "△" on parts list are used at voltages more than 250V.

Removal of the outer wrap gives access to voltage above 250V.

All the parts marked "" on parts list may cause undue microwave exposure, by themselves, or when they are damaged, loosened or removed.

CHAPTER 4. PRODUCT DESCRIPTION

[1] SPECIFICATIONS

ITEM	DESCRIPTION
Power Requirements	120 Volts 14 Amperes 60 Hertz Single phase, 3 wire grounded
Power Output	1000 watts (IEC Test procedure) Operating frequency 2450 MHz
Outer Case Dimensions	Width 20-1/2" (520mm) Height 12-1/8" (309mm) Depth 16" (406mm)
Cooking Cavity Dimensions	Width 13-7/8" (353mm) NOTE: Internal capacity is calculated by measuring maximum width, depth and height. Height 8-1/8" (207mm) Actual capacity for holding food is less. Depth 14-5/8" (370mm)
Control Complement	Touch Control System Timer (0 - 99 minutes 99 seconds) Microwave Power for Variable Cooking Repetition Rate; P-HI ----- Full power throughout the cooking time P-90 ----- approx. 90% of FULL Power P-80 ----- approx. 80% of FULL Power P-70 ----- approx. 70% of FULL Power P-60 ----- approx. 60% of FULL Power P-50 ----- approx. 50% of FULL Power P-40 ----- approx. 30% of FULL Power P-30 ----- approx. 40% of FULL Power P-20 ----- approx. 20% of FULL Power P-10 ----- approx. 10% of FULL Power P-0 ----- No power throughout the cooking time DOUBLE QUANTITY pad EXPRESS DEFROST pad Ten number pads SELECTATIME pad STOP/CLEAR pad SELECTAPOWVER pad (R-21LTF only) START pad SET pad CHECK pad SIGNAL pad
Oven Cavity Light	Yes
Safety Standard	UL Listed. FCC Authorized DHHS Rules, CFR, Title 21, Chapter 1, Subchapter J, NSF certified

CHAPTER 5. GENERAL INFORMATION

[1] GROUNDING INSTRUCTIONS

This oven is equipped with a three prong grounding plug. It must be plugged into a wall receptacle that is properly installed and grounded in accordance with the National Electrical Code and local codes and ordinances.

In the event of an electrical short circuit, grounding reduces the risk of electric shock by providing an escape wire for the electric current.

WARNING: Improper use of the grounding plug can result in a risk of electric shock.

Electrical Requirements

The electrical requirements are a 120 volt 60 Hz, AC only, 15 amp. or more protected electrical supply. It is recommended that a separate circuit serving only this appliance be provided. When installing this appliance, observe all applicable codes and ordinances. A short power-supply cord is provided to reduce risks of becoming entangled in or tripping over a longer cord. Where a two-pronged wall-receptacle is encountered, it is the personal responsibility and obligation of the customer to contact a qualified electrician and have it replaced with a properly grounded three-pronged wall receptacle or have a grounding adapter properly grounded and polarized. If the extension cord must be used, it should be a 3-wire, 15 amp. or higher rated cord. Do not drape over a countertop or table where it can be pulled on by children or tripped over accidentally.

CAUTION: DO NOT UNDER ANY CIRCUMSTANCES CUT OR REMOVE THE ROUND GROUNDING PRONG FROM THIS PLUG.

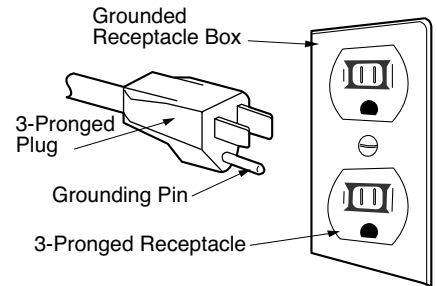

[2] OVEN DIAGRAM

1. OVEN

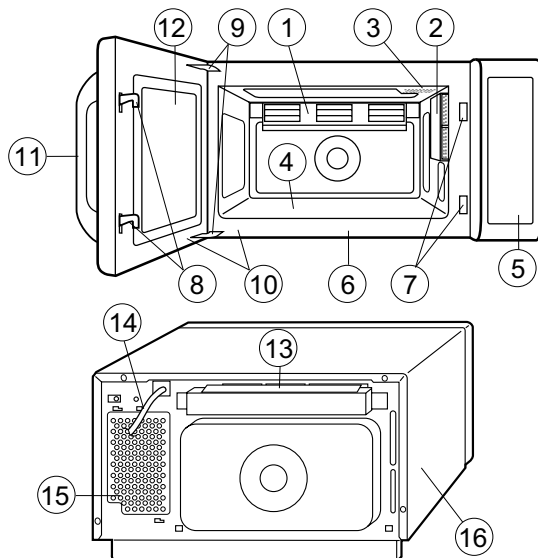

1. Back splash cover
2. Side splash cover
3. Oven light
4. Ceramic shelf
5. Control panel
6. Cavity face plate
7. Door latch openings
8. Door latches
9. Door hinges
10. Door seals and sealing surfaces
11. Door handle
12. Oven door with see-through window
13. Air ventilation cover and openings
14. Power supply cord
15. Air intake openings
16. Outer case cabinet

2. TOUCH CONTROL PANEL

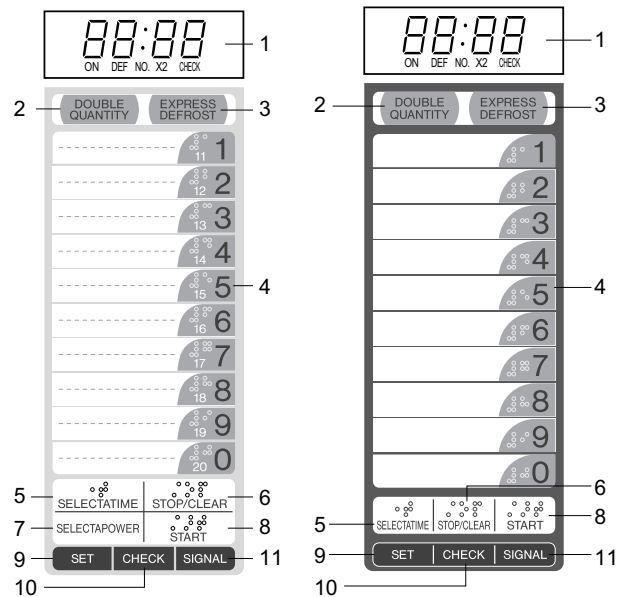

R-21LTF

R-21LVF

1. Digital Readout
2. DOUBLE QUANTITY pad
3. EXPRESS DEFROST pad
4. Ten number pads for time and memory programming
5. SELECT TIME pad
6. STOP/CLEAR pad; touch to stop operation of oven and clear remaining heating time
7. SELECT POWER pad for setting variable power level (R-21LTF only)
8. START pad; touch to operate oven after door is closed and time is set
9. SET pad for setting memory
10. CHECK pad for checking memory
11. SIGNAL pad for setting signal sound

CHAPTER 6. OPERATION

[1] DESCRIPTION OF OPERATING SEQUENCE

The following is a description of component functions during oven operation.

1. OFF CONDITION

Closing the door activates door sensing switch and secondary interlock switch. (In this condition, the monitor switch contacts are opened.)

When oven is plugged in, 120 volts A.C. is supplied to noise filter of the control unit (Figure O-1).

- 1) The display will show " . ".

2. COOKING CONDITION

Program desired cooking time by touching SELECTATIME pad and the NUMBER pads. When the START pad is touched, the following operations occur:

- 1) The contacts of the relays are closed and components connected to the relays are turned on as follows.

(For details, refer to Figure O-2)

RELAY	CONNECTED COMPONENTS
RY-2	power transformer
RY-3	oven lamp/antenna motor/fan motor

- 2) 120 volts A.C. is supplied to the primary winding of the power transformer and is converted to about 3.2 volts A.C. output on the filament winding, and approximately 2150 volts A.C. on the high voltage winding.
- 3) The filament winding voltage heats the magnetron filament and the H.V. winding voltage is sent to a voltage doubler circuit.
- 4) The microwave energy produced by the magnetron is channelled through the waveguide into the cavity feed-box, and then into the cavity where the food is placed to be cooked.
- 5) Upon completion of the cooking time, the power transformer, oven lamp, etc. are turned off, and the generation of microwave energy is stopped. The oven will revert to the OFF condition.
- 6) When the door is opened during a cook cycle, monitor switch, door sensing switch, secondary interlock switch, relay (RY3) and primary interlock relay (RY2) are activated with the following results. The circuits to the antenna motor, the cooling fan motor, and the high voltage components are de-energized, the oven lamp remains on, and the digital read-out displays the time still remaining in the cook cycle when the door was opened.
- 7) The monitor switch electrically monitors the operation of the secondary interlock switch and control relay (RY3) and is mechanically associated with the door so that it will function in the following sequence.
 - a) When the door opens from the closed position, the primary interlock relay (RY2) and secondary interlock switch open their contacts. And contacts of the relay (RY3) remains closed. Then the monitor switch contacts close.
 - b) When the door is closed from the open position, the monitor switch contacts open first. Then the contacts of the secondary interlock switch and door sensing switch close and contacts of the relay (RY3) open.

If the secondary interlock switch and primary interlock relay (RY2) fail with the contacts closed when the door is opened, the closing of the monitor switch contacts will form a short circuit through the monitor fuse, secondary interlock switch, relay (RY3) and primary interlock relay (RY2), causing the monitor fuse to blow.

3. POWER LEVEL P-0 TO P-90 COOKING (R-21LTF only)

When Variable Cooking Power is programmed, the 120 volts A.C. is supplied to the power transformer intermittently through the contacts of relay (RY-2) which is operated by the control unit within a 32 second time base. Microwave power operation is as follows:

VARI-MODE	ON TIME	OFF TIME
Power 10 (P-HI) (100% power)	32 sec.	0 sec.
Power 9 (P-90) (approx. 90% power)	30 sec.	2 sec.
Power 8 (P-80) (approx. 80% power)	26 sec.	6 sec.
Power 7 (P-70) (approx. 70% power)	24 sec.	8 sec.
Power 6 (P-60) (approx. 60% power)	22 sec.	10 sec.
Power 5 (P-50) (approx. 50% power)	18 sec.	14 sec.
Power 4 (P-40) (approx. 40% power)	16 sec.	16 sec.
Power 3 (P-30) (approx. 30% power)	12 sec.	20 sec.
Power 2 (P-20) (approx. 20% power)	8 sec.	24 sec.
Power 1 (P-10) (approx. 10% power)	6 sec.	26 sec.
Power 0 (P-0) (0% power)	0 sec.	32 sec.

NOTE: The ON/OFF time ratio does not correspond with the percentage of microwave power, because approx. 2 seconds are needed for heating of the magnetron filament.

R21LTF

[2] OVEN SCHEMATIC

1. Off Condition

SCHEMATIC
NOTE: CONDITION OF OVEN
1. DOOR CLOSED
2. " . " APPEARED

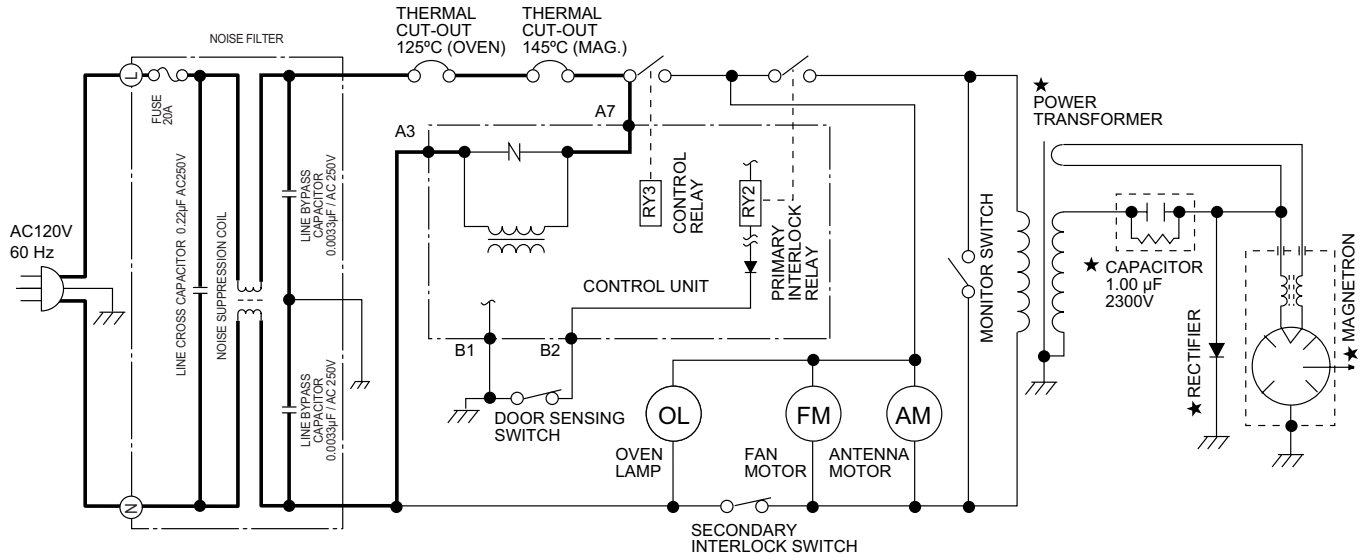

Figure O-1. Oven Schematic-Off Condition

2. Cooking Condition

SCHEMATIC
NOTE: CONDITION OF OVEN
1. DOOR CLOSED.
2. SELECTATIME PAD TOUCHED.
3. COOKING TIME ENTERED.
4. START PAD TOUCHED.

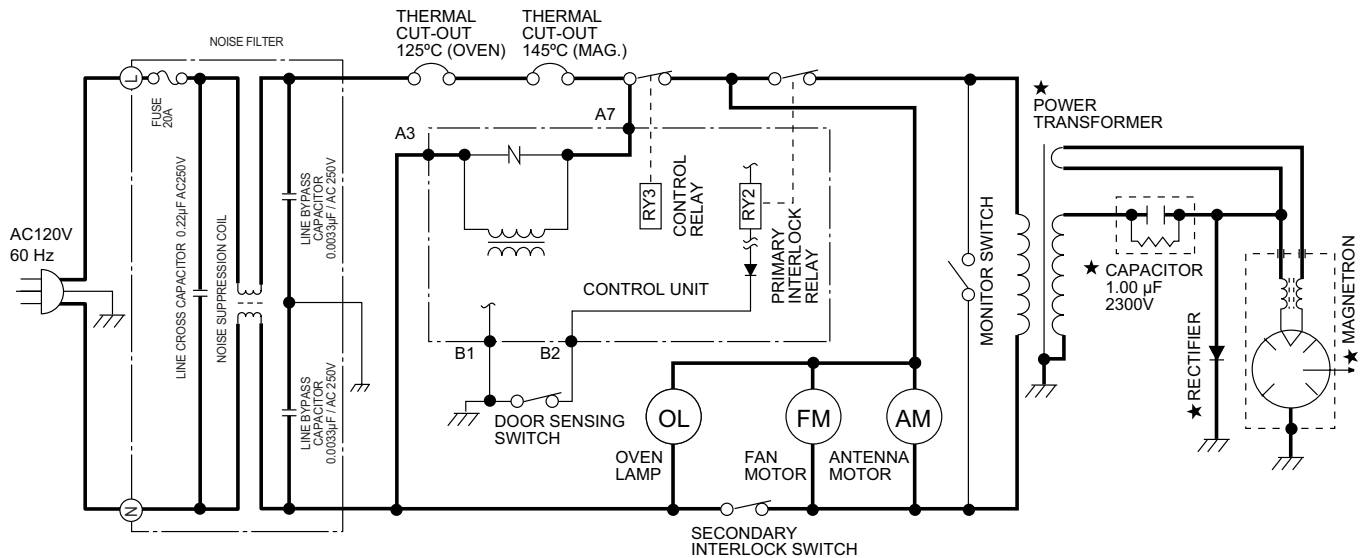

Figure O-2. Oven Schematic-Cooking Condition

[3] DESCRIPTION AND FUNCTION OF COMPONENTS

1. DOOR OPEN MECHANISM

The door is opened by grasping the door handle, refer to Figure D-1.

When the door handle is grasped, the handle lever is pulled. And then the upper and lower latch heads are moved upward by the handle lever, and they are released from the latch hook. Now the door will open.

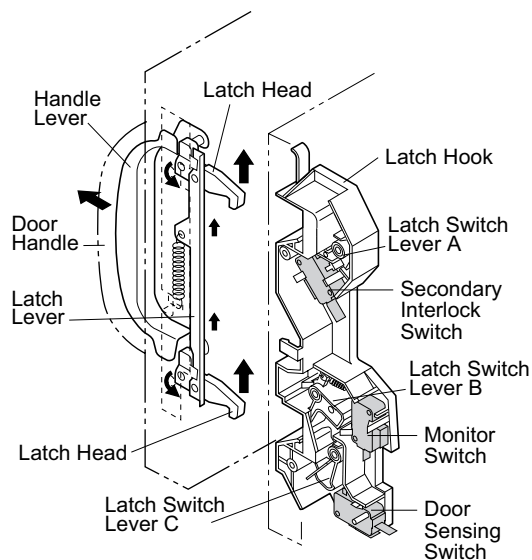

Figure D-1. Door Open Mechanism.

2. DOOR SENSING AND SECONDARY INTERLOCK SWITCHES

The secondary interlock switch is mounted in the upper position of the latch hook and the door sensing switch in the primary interlock system is mounted in the lower position of the latch hook. The secondary interlock switch is activated by the latch switch lever A. The latch switch lever A is activated by the upper latch head. The door sensing switch is activated by the latch switch lever C. The latch switch lever C is activated by the lower latch head. When the door is opened, the switches interrupt the power to all high voltage components. A cook cycle cannot take place until the door is firmly closed thereby activating both interlock switches. The primary interlock system consists of the door sensing switch and primary interlock relay located on the control circuit board.

3. MONITOR SWITCH

The monitor switch is activated (the contacts opened) by the latch switch lever B on the latch hook while the door is closed. The latch switch lever B is activated by the lower latch head. The switch is intended to render the oven inoperative, by means of blowing the monitor fuse, when the contacts of the primary interlock relay (RY2) and secondary interlock switch fail to open when the door is opened.

Functions:

- 1) When the door is opened, the monitor switch contacts close (to the ON condition) due to their being normally closed. At this time the primary interlock relay (RY2) and secondary interlock switch are in the OFF condition (contacts open) due to their being normally open contact switches.
- 2) As the door goes to a closed position, the monitor switch contacts are first opened and then the door sensing switch and the secondary interlock switch contacts close. (On opening the door, each of these switches operate inversely.)
- 3) If the door is opened, and the primary interlock relay (RY2) and secondary interlock switch contacts fail to open, the monitor fuse blows simultaneously with closing of the monitor switch contacts.

CAUTION: BEFORE REPLACING A BLOWN MONITOR FUSE TEST THE DOOR SENSING SWITCH, PRIMARY INTERLOCK RELAY (RY2), RELAY (RY3) SECONDARY INTERLOCK SWITCH AND MONITOR SWITCH FOR PROPER OPERATION. (REFER TO CHAPTER "TEST PROC

NOTE: MONITOR FUSE AND MONITOR SWITCH ARE REPLACED AS AN ASSEMBLY.

4. ANTENNA MOTOR

The antenna motor rotates the stirrer antenna located on the bottom of the oven cavity, so that the food on the ceramic shelf is cooked evenly during cooking. The antenna motor may turn in either direction.

5. COOLING FAN MOTOR

The cooling fan motor drives a blade which draws external cool air. This cool air is directed through the air vanes surrounding the magnetron and cools the magnetron. This air is channelled through the oven cavity to remove steam and vapors given off from the heating food. It is then exhausted through the exhausting air vents at the oven cavity.

6. MONITOR FUSE

- 1) The monitor fuse blows when the contacts (COM-NO) of the primary interlock relay (RY2) and secondary interlock switch remain closed with the oven door open and when the monitor switch closes.
- 2) If the wire harness or electrical components are shortcircuited, this monitor fuse blows to prevent an electric shock or fire hazard.

7. THERMAL CUT-OUT 145°C (MAGNETRON)

This thermal cut-out protects the magnetron against overheating. If the temperature goes up higher than 293°F (145°C) because the fan motor is interrupted or the ventilation openings are blocked, the thermal cut-out will open and line voltages to the high voltage transformer will be cut off and the operation of the magnetron will be stopped. The thermal cutout will not resume.

8. THERMAL CUT-OUT 125°C (OVEN)

The thermal cut-out located on the top of the oven cavity is designed to prevent damage to the oven if the food in the oven catches fire due to over heating produced by improper setting of the cooking time or failure of control unit. Under normal operation, the oven thermal cut-out remains closed. However, when abnormally high temperatures are reached within the oven cavity, the oven thermal cut-out will open at 257°F(125°C) causing the oven to shut down. The thermal cut-out will not resume.

9. NOISE FILER

The noise filter prevents the radio frequency interference that might flow back in the power circuit.

CHAPTER 7. TROUBLESHOOTING GUIDE

Never touch any part in the circuit with your hand or an uninsulated tool while the power supply is connected.

When troubleshooting the microwave oven, it is helpful to follow the Sequence of Operation in performing the checks. Many of the possible causes of trouble will require that a specific test be performed. These tests are given a procedure letter which will be found in the "Test Procedure" section.

IMPORTANT:

If the oven becomes inoperative because of a blown monitor fuse, check the monitor switch, relay (RY3), primary interlock relay (RY2), door sensing switch and secondary interlock switch before replacing the monitor fuse. If monitor fuse is replaced, the monitor switch must also be replaced. Use part FFS-BA033WRKZ as an assembly.

IMPORTANT:

Whenever troubleshooting is performed with the power supply cord disconnected. It may in, some cases, be necessary to connect the power supply cord after the outer case has been removed, in this event,

- 1) Disconnect the power supply cord, and then remove outer case.
- 2) Open the door and block it open.
- 3) Discharge high voltage capacitor.

- 4) Disconnect the leads to the primary of the power transformer.
- 5) Ensure that the leads remain isolated from other components and oven chassis by using insulation tape.
- 6) After that procedure, reconnect the power supply cord.

When the testing is completed,

- 1) Disconnect the power supply cord, and then remove outer case.
- 2) Open the door and block it open.
- 3) Discharge high voltage capacitor.
- 4) Reconnect the leads to the primary of the power transformer.
- 5) Reinstall the outer case (cabinet).
- 6) Reconnect the power supply cord after the outer case is installed.
- 7) Run the oven and check all functions.

[1] TROUBLESHOOTING CHART

TEST PROCEDURE		A	B	C	D	E	F	F	G	H	J	K	L	M	CK	RE	RE	RE	RE	RE	CK	CK	CK	I	
POSSIBLE CASE AND DEFECTIVE PARTS		MAGNETRON	POWER TRANSFORMER	H.V. RECTIFIER ASSEMBLY	HIGH VOLTAGE CAPACITOR	THERMAL CUT-OUT	SECONDARY INTERLOCK SWITCH	PRIMARY INTERLOCK SYSTEM	MONITOR SWITCH	MONITOR FUSE	TOUCH CONTROL PANEL	KEY UNIT	RELAY (RY3)	FOIL PATTERN ON P.W.B.	EXCEED MAX. HEATING TIME	OVEN LAMP OR SOCKET	COOLING FAN MOTOR	ANTENNA MOTOR	SHORTED IN POWER CORD	SHORT OR OPENED WIRING	WRONG OPERATION	LOW VOLTAGE	DIRTY OVEN CAVITY	NOISE FILTER	
CONDITION	PROBLEM																								
OFF CONDITION	Home fuse or circuit breaker blows when power cord is plugged into wall outlet.																								
	Monitor fuse blows when power cord is plugged into wall receptacle.							●	●	●	●														●
	_____ does not appear in display when power cord is first plugged into wall outlet.					●					●	●		●											●
	Oven lamp does not light when door is opened.									●						●									●
COOKING CONDITION	Oven lamp does not go out when door is closed.								●					●											
	Oven lamp lights but fan motor and antenna motor do not operate.																●	●							
	Oven does not go into cook cycle when START pad is touched							●	●			●	●								●	●			
	Oven seems to be operating but little or no heat is produced in oven load. (Food incompletely cooked or not cooked at all at end of cook cycle.)	●	●	●	●					●		●													●
	Oven goes into a cook cycle but extremely uneven heating is produced in oven load (food).																	●			●	●	●	●	
	Oven does not cook properly when programmed for Cooking Power 5 mode. (Operates properly on Cooking Power 10 (HIGH) mode.)														●										
ERROR MODE	"EE9" Maximum time is exceeded.											●			●										

CHAPTER 8. TEST PROCEDURES

[1] Procedure A: MAGNETRON ASSEMBLY TEST

1. Disconnect the power supply cord, and then remove outer case.
2. Open the door and block it open.
3. Discharge high voltage capacitor.
4. To test for an open filament, isolate the magnetron from the high voltage circuit. A continuity check across the magnetron filament leads should indicate less than 1 ohm.
5. To test for a shorted magnetron, connect the ohmmeter leads between the magnetron filament leads and chassis ground. This test should indicate an infinite resistance. If there is little or no resistance the magnetron is grounded and must be replaced.
6. Reconnect all leads removed from components during testing.
7. Reinstall the outer case (cabinet).
8. Reconnect the power supply cord after the outer case is installed.
9. Run the oven and check all functions.

1. MICROWAVE OUTPUT POWER

The following test procedure should be carried out with the microwave oven in a fully assembled condition (outer case fitted).

HIGH VOLTAGES ARE PRESENT DURING THE COOK CYCLE, SO EXTREME CAUTION SHOULD BE OBSERVED.

Power output of the magnetron can be measured by performing a water temperature rise test. This test should only be used if above tests do not indicate a faulty magnetron and there is no defect in the following components or wiring: silicon rectifier, high voltage capacitor and power transformer. This test will require a 16 ounce (453cc) measuring cup and an accurate mercury thermometer or thermocouple type temperature tester. For accurate results, the following procedure must be followed carefully:

1. Fill the measuring cup with 16 oz. (453cc) of tap water and measure the temperature of the water with a thermometer or thermocouple temperature tester. Stir the thermometer or thermocouple through the water until the temperature stabilizes. Record the temperature of the water.
2. Place the cup of water in the oven. Operate oven at POWER 10 (HIGH) selecting more than 60 seconds cook time. Allow the water to heat for 60 seconds, measuring with a stop watch, second hand of a watch or the digital read-out countdown.
3. Remove the cup from the oven and again measure the temperature, making sure to stir the thermometer or thermocouple through the water until the maximum temperature is recorded.
4. Subtract the cold water temperature from the hot water temperature. The normal result should be 34.7 to 64.6°F(19.3 to 35.9°C) rise in temperature. If the water temperatures are accurately measured and tested for the required time period the test results will indicate if the magnetron tube has low power output (low rise in water temperature) which would extend cooking time or high power output (high rise in water temperature) which would reduce cooking time. Because cooking time can be adjusted to compensate for power output, the magnetron tube assembly should be replaced only if the water temperature rise test indicates a power output well beyond the normal limits. The test is only accurate if the power supply line voltage is 120 volts and the oven cavity is clean.

[2] Procedure B: POWER TRANSFORMER TEST

1. Disconnect the power supply cord, and then remove outer case.
2. Open the door and block it open.
3. Discharge high voltage capacitor.
4. Disconnect the primary input terminals and measure the resistance of the transformer with an ohmmeter. Check for continuity of the coils with an ohmmeter. On the R x 1 scale, the resistance of the primary coil should be less than 1 ohm and the resistance of the high voltage coil should be approximately 83.7 ohms; the resistance of the filament coil should be less than 1 ohm.
5. Reconnect all leads removed from components during testing.
6. Reinstall the outer case (cabinet).
7. Reconnect the power supply cord after the outer case is installed.
8. Run the oven and check all functions.

(HIGH VOLTAGES ARE PRESENT AT THE HIGH VOLTAGE TERMINAL, SO DO NOT ATTEMPT TO MEASURE THE FILAMENT AND HIGH VOLTAGE.)

[3] Procedure C: HIGH VOLTAGE RECTIFIER TEST

1. Disconnect the power supply cord, and then remove outer case.
2. Open the door and block it open.
3. Discharge high voltage capacitor.
4. Isolate the rectifier from the circuit. Using the highest ohm scale of the meter, read the resistance across the terminals and observe, reverse the leads to the rectifier terminals and observe meter reading. If a short is indicated in both directions, or if an infinite resistance is read in both directions, the rectifier is probably defective and should be replaced.
5. Reconnect all leads removed from components during testing.

R21LTF

6. Reinstall the outer case (cabinet).
7. Reconnect the power supply cord after the outer case is installed.
8. Run the oven and check all functions.

NOTE: **Be sure to use an ohmmeter that will supply a forward bias voltage of more than 6.3 volts.**

[4] Procedure D: HIGH VOLTAGE CAPACITOR TEST

1. Disconnect the power supply cord, and then remove outer case.
2. Open the door and block it open.
3. Discharge high voltage capacitor.
4. If the capacitor is open, no high voltage will be available to the magnetron. Disconnect input leads and check for short or open between the terminals using an ohmmeter.

Checking with a high ohm scale, if the high voltage capacitor is normal, the meter will indicate continuity for a short time and should indicate an open circuit once the capacitor is charged. If the above is not the case, check the capacitor with an ohmmeter to see if it is shorted between either of the terminals and case. If it is shorted, replace the capacitor.

5. Reconnect all leads removed from components during testing.
6. Reinstall the outer case (cabinet).
7. Reconnect the power supply cord after the outer case is installed.
8. Run the oven and check all functions.

[5] Procedure E: THERMAL CUT OUT TEST

1. THERMAL CUT OUT 125°C (OVEN)

1. Disconnect the power supply cord, and then remove outer case.
2. Open the door and block it open.
3. Discharge high voltage capacitor.
4. A continuity check across the thermal cut-out terminals should indicate a closed circuit unless the temperature of the thermal cut-out reaches approximately 257°F(125°C). An open thermal cut-out indicates overheating of the oven, exchange the thermal cut-out and check inside of oven cavity and for improper setting of cooking time or operation of control unit. Check for restricted air flow through the vent holes of the oven cavity, especially the cooling fan and air guide.
5. Reconnect all leads removed from components during testing.
6. Reinstall the outer case (cabinet).
7. Reconnect the power supply cord after the outer case is installed.
8. Run the oven and check all functions.

2. THERMAL CUT OUT 145°C (MAGNETRON)

1. Disconnect the power supply cord, and then remove outer case.
2. Open the door and block it open.
3. Discharge high voltage capacitor.
4. A continuity check across the thermal cut-out terminals should indicate a closed circuit. If the temperature of the magnetron reaches approximately 293°F(145°C), the thermal cut-out opens. An open thermal cutout indicates overheating of the magnetron. Check for restricted air flow to the magnetron, especially the cooling fan air guide.
5. Reconnect all leads removed from components during testing.
6. Reinstall the outer case (cabinet).
7. Reconnect the power supply cord after the outer case is installed.
8. Run the oven and check all functions.

CAUTION: IF THE THERMAL CUT-OUT INDICATES AN OPEN CIRCUIT AT ROOM TEMPERATURE,
REPLACE THERMAL CUT-OUT.

[6] Procedure F: SECONDARY INTERLOCK SWITCH TEST

1. Disconnect the power supply cord, and then remove outer case.
2. Open the door and block it open.
3. Discharge high voltage capacitor.
4. Isolate the switch and connect the ohmmeter to the common (COM.) and normally open (NO) terminal of the switch. The meter should indicate an open circuit with the door open and a closed circuit with the door closed. If improper operation is indicated, replace the secondary interlock switch.
5. Reconnect all leads removed from components during testing.
6. Reinstall the outer case (cabinet).

7. Reconnect the power supply cord after the outer case is installed.
8. Run the oven and check all functions.

[7] Procedure F: PRIMARY INTERLOCK SYSTEM TEST

1. DOOR SENSING SWITCH

1. Disconnect the power supply cord, and then remove outer case.
2. Open the door and block it open.
3. Discharge high voltage capacitor.
4. Isolate the switch and connect the ohmmeter to the common (COM.) and normally open (NO) terminal of the switch. The meter should indicate an open circuit with the door open and a closed circuit with the door closed. If improper operation is indicated, replace the door sensing switch.
5. Reconnect all leads removed from components during testing.
6. Reinstall the outer case (cabinet).
7. Reconnect the power supply cord after the outer case is installed.
8. Run the oven and check all functions.

2. PRIMARY INTERLOCK RELAY (RY2)

1. Disconnect the power supply cord, and then remove outer case.
2. Open the door and block it open.
3. Discharge high voltage capacitor.
4. Disconnect two (2) wire leads from the male tab terminals of the Primary Interlock Relay. Check the state of the relay contacts using a ohmmeter. The relay contacts should be open. If the relay contacts are closed, replace the circuit board entirely or the relay itself.
5. Reconnect all leads removed from components during testing.
6. Reinstall the outer case (cabinet).
7. Reconnect the power supply cord after the outer case is installed.
8. Run the oven and check all functions.

[8] Procedure G: MONITOR SWITCH TEST

1. Disconnect the power supply cord, and then remove outer case.
2. Open the door and block it open.
3. Discharge high voltage capacitor.
4. Before performing this test, make sure that the secondary interlock switch and the primary interlock relay are operating properly, according to the above Switch Test Procedure. Disconnect the wire lead from the monitor switch (COM) terminal. Check the monitor switch operation by using the ohmmeter as follows. When the door is open, the meter should indicate a closed circuit. When the monitor switch actuator is pushed by a screw driver through the lower latch hole on the front plate of the oven cavity with the door opened (in this condition the plunger of the monitor switch is pushed in), the meter should indicate an open circuit. If improper operation is indicated, the switch may be defective. After testing the monitor switch, reconnect the wire lead to the monitor switch (COM) terminal and check the continuity of the monitor circuit.
5. Reconnect all leads removed from components during testing.
6. Reinstall the outer case (cabinet).
7. Reconnect the power supply cord after the outer case is installed.
8. Run the oven and check all functions.

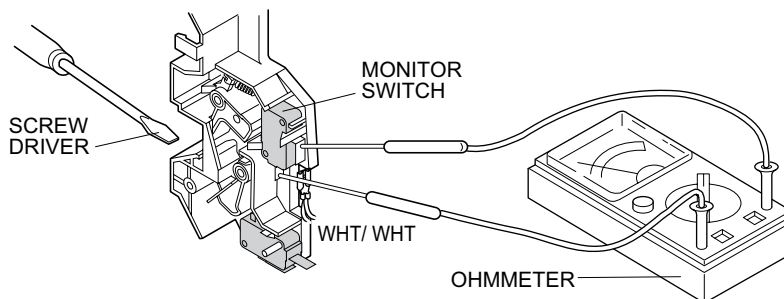

[9] Procedure H: BLOWN MINITOR FUSE TEST

1. Disconnect the power supply cord, and then remove outer case.
2. Open the door and block it open.
3. Discharge high voltage capacitor.

R21LTF

- If the monitor fuse is blown when the door is opened, check the primary interlock relay, secondary interlock switch and monitor switch according to the "TEST PROCEDURE" for those switches before replacing the blown monitor fuse.

CAUTION: BEFORE REPLACING A BLOWN MONITOR FUSE, TEST THE PRIMARY INTERLOCK RELAY, SECONDARY INTERLOCK SWITCH, DOOR SENSING SWITCH AND MONITOR SWITCH FOR PROPER OPERATION.

If the monitor fuse is blown by improper switch operation, the monitor fuse and monitor switch must be replaced with "monitor fuse and monitor switch assembly" part number FFS-BA033WRKZ, even if the monitor switch operates normally. The monitor fuse and monitor switch assembly is comprised of a 20 ampere fuse and switch.

- Reconnect all leads removed from components during testing.
- Reinstall the outer case (cabinet).
- Reconnect the power supply cord after the outer case is installed.
- Run the oven and check all functions.

[10] Procedure I: NOISE FILTER TEST

- Disconnect the power supply cord, and then remove outer case.
- Open the door and block it open.
- Discharge high voltage capacitor.
- Disconnect the lead wires from the terminal the noise filter. Using an ohmmeter, check between the terminals as described in the following table. If incorrect reading are obtained, replace the noise filter.
- Reconnect all leads removed from components during testing.
- Reinstall the outer case (cabinet).
- Reconnect the power supply cord after the outer case is installed.
- Run the oven and check all functions.

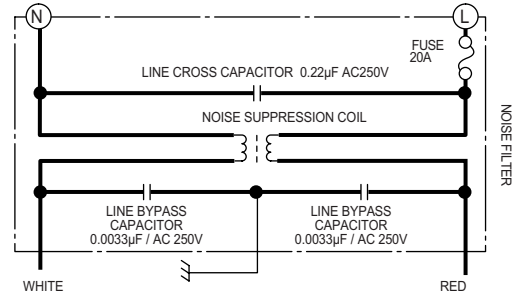

MEASURING POINT	INDICATION OF OHMMETER
Between N and L	Open circuit.
Between terminal N and WHITE	Short circuit.
Between terminal L and RED	Short circuit.

[11] Procedure J: TOUCH CONTROL PANEL ASSEMBLY TEST

The touch control panel consists of circuits including semiconductors such as LSI, ICs, etc. Therefore, unlike conventional microwave ovens, proper maintenance cannot be performed with only a voltmeter and ohmmeter.

In this service manual, the touch control panel assembly is divided into two units, Control Unit and Key Unit, and troubleshooting by unit replacement is described according to the symptoms indicated.

Before testing,

- Disconnect the power supply cord and then remove outer case.
- Open the door and block it open.
- Discharge high voltage capacitor.
- Disconnect the leads to the primary of the power transformer.
- Ensure that these leads remain isolated from other components and oven chassis by using insulation tape.
- After that procedure, re-connect the power supply cord.

1. Key Unit

NOTE:

- Disconnect the power supply cord and then remove outer case.
- Open the door and block it open.
- Discharge high voltage capacitor.
- Check key unit ribbon connection before replacement.
- Reconnect all leads removed from components during testing.
- Re-install the outer case (cabinet).
- Reconnect the power supply cord after the outer case is installed.
- Run the oven and check all functions.

The following symptoms indicate a defective key unit.

- When touching the pads, a certain pad produces no signal at all.
- When touching a number pad, two figures or more are displayed.
- When touching the pads, sometimes a pad produces no signal.

If the key unit is defective.

- 1) Disconnect the power supply cord and then remove outer case.
- 2) Open the door and block it open.
- 3) Discharge high voltage capacitor.
- 4) Replace the key unit.
- 5) Reconnect all leads removed from components during testing.
- 6) Re-install the outer case (cabinet).
- 7) Reconnect the power supply cord after the outer case is installed.
- 8) Run the oven and check all functions.

2. Control Unit.

The following symptoms indicate a defective control unit. Before replacing the control unit, perform the Key unit test (Procedure K) to determine if control unit is faulty.

- 1) In connection with pads.
 - a) When touching the pads, a certain group of pads do not produce a signal.
 - b) When touching the pads, no pads produce a signal.
- 2) In connection with indicators
 - a) At a certain digit, all or some segments do not light up.
 - b) At a certain digit, brightness is low.
 - c) Only one indicator does not light.
 - d) The corresponding segments of all digits do not light up; or they continue to light up.
 - e) Wrong figure appears.
 - f) A certain group of indicators do not light up.
 - g) The figure of all digits flicker.
- 3) Other possible problems caused by defective control unit.
 - a) Buzzer does not sound or continues to sound.
 - b) Clock does not operate properly.
 - c) Cooking is not possible.

When testing is completed,

- 1) Disconnect the power supply cord and then remove outer case.
- 2) Open the door and block it open.
- 3) Discharge high voltage capacitor.
- 4) Reconnect all leads removed from components during testing.
- 5) Re-install the outer case (cabinet).
- 6) Reconnect the power supply cord after the outer case is installed.
- 7) Run the oven and check all functions.

[12] Procedure K: KEY UNIT TEST

1. Disconnect the power supply cord, and then remove outer case.
2. Open the door and block it open.
3. Discharge high voltage capacitor.
4. If the display fails to clear when the STOP/CLEAR pad is depressed, first verify the flat ribbon cable is making good contact, verify that the door sensing switch (stop switch) operates properly; that is the contacts are closed when the door is closed and open when the door is open. If the door sensing switch (stop switch) is good, disconnect the flat ribbon cable that connects the key unit to the control unit and make sure the door sensing switch is closed (either close the door or short the door sensing switch connector). Use the Key unit matrix indicated on the control panel schematic and place a jumper wire between the pins that correspond to the STOP/CLEAR pad making momentary contact. If the control unit responds by clearing with a beep the key unit is faulty and must be replaced. If the control unit does not respond, it is faulty and must be replaced. If a specific pad does not respond, the above method may be used (after clearing the control unit) to determine if the control unit or key pad is at fault.
5. Reconnect all leads removed from components during testing.
6. Reinstall the outer case (cabinet).
7. Reconnect the power supply cord after the outer case is installed.
8. Run the oven and check all functions.

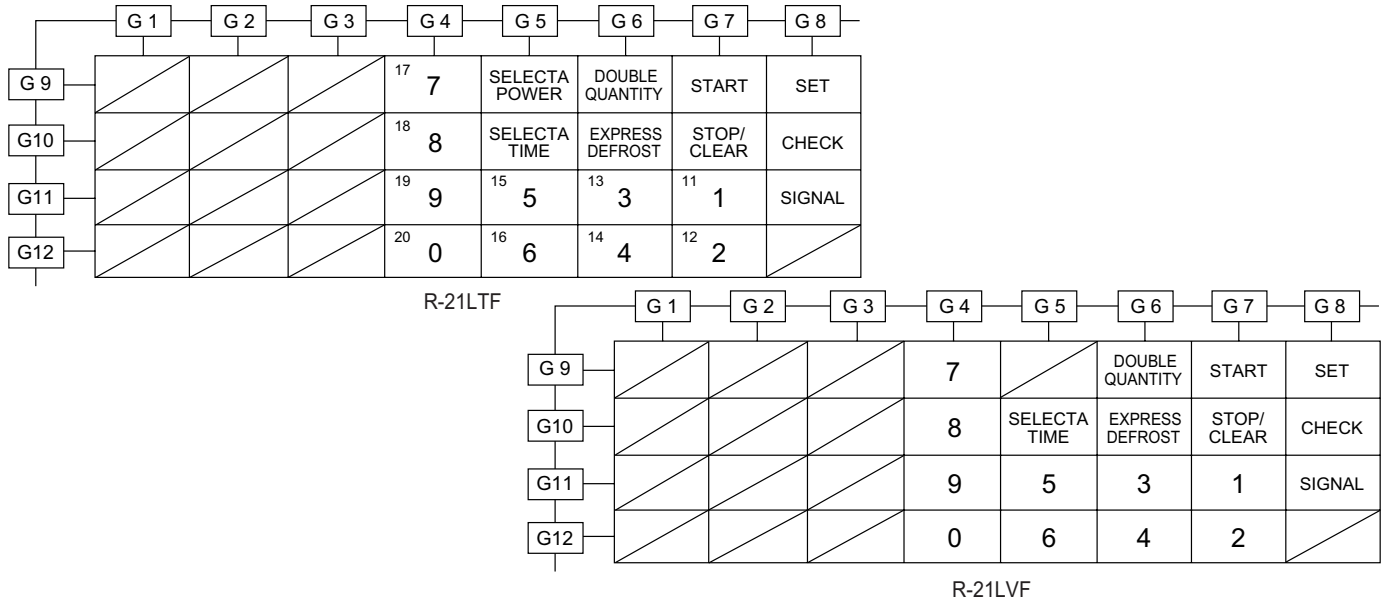

[13] Procedure L: RELAY TEST

1. Disconnect the power supply cord, and then remove outer case.
2. Open the door and block it open.
3. Discharge high voltage capacitor.
4. Disconnect the leads to the primary of the power transformer.
5. Ensure that these leads remain isolated from other components and oven chassis by using insulation tape.
6. After that procedure, re-connect the power supply cord.
7. Remove the outer case and check voltage between Pin Numbers. 3 and 7 of the connector (A) on the control unit with an A.C. voltmeter.
The meter should indicate 120 volts, if not check oven circuit.

RY2 and RY3 Relay Test

These relays are operated by D.C. voltage

Check voltage at the relay coil with a D.C. voltmeter during the microwave cooking operation.

DC. voltage indicated Defective relay.

DC. voltage not indicated Check diode which is connected to the relay coil. If diode is good, control unit is defective.

RELAY SYMBOL	OPERATIONAL VOLTAGE	CONNECTED COMPONENTS
RY2	Approx. 12.0V D.C.	Power transformer
RY3	Approx. 12.0V D.C.	Oven lamp / Antenna motor / Cooling fan motor

8. Disconnect the power supply cord and then remove outer case.
9. Open the door and block it open.
10. Discharge high voltage capacitor.
11. Reconnect all leads removed from components during testing.
12. Re-install the outer case (cabinet).
13. Reconnect the power supply cord after the outer case is installed.
14. Run the oven and check all functions.

[14] Procedure M: FOIL PATTERN ON THE PRINTED WIRING BOARD TEST

To protect the electronic circuits, this model is provided with a fine foil pattern added to the primary on the PWB, this foil pattern acts as a fuse.

1. Foil pattern check and repairs.
 - 1) Disconnect the power supply cord and then remove outer case.
 - 2) Open the door and block it open.
 - 3) Discharge high voltage capacitor.
 - 4) Follow the troubleshooting guide given below for repair.

STEPS	OCCURRENCE	CAUSE OR CORRECTION
-------	------------	---------------------

1	Only pattern at "a" is broken.	*Insert jumper wire J1 and solder.
2	Pattern at "a" and "b" are broken.	*Replace control unit.

5) Make a visual inspection of the varistor. Check for burned damage and examine the transformer with a tester for the presence of layer short-circuit (check the primary coil resistance which is approximately $915\Omega \pm 10\%$). If any abnormal condition is detected, replace the control unit.

6) Reconnect all leads removed from components during testing.

7) Re-install the outer case (cabinet).

8) Reconnect the power supply cord after the outer case is installed.

9) Run the oven and check all functions.

2. Follow the troubleshooting guide given below, if indicator does not light up after above check and repairs are finished.

1) Disconnect the power supply cord and then remove outer case.

2) Open the door and block it open.

3) Discharge high voltage capacitor.

4) Disconnect the leads to the primary of the power transformer.

5) Ensure that these leads remain isolated from other components and oven chassis by using insulation tape.

6) After that procedure, re-connect the power supply cord.

7) Follow the troubleshooting guide given below for repair.

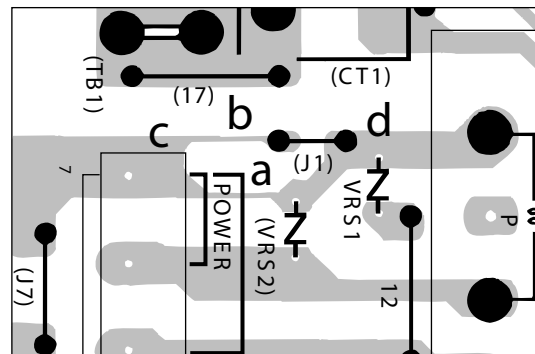

STEPS	OCCURRENCE	CAUSE OR CORRECTION
1	The rated AC voltage is not present between Pin No. 1 of the 3-pin connector (A) and the normal open terminal of the relay RY2	Check supply voltage and oven power cord.
2	The rated AC voltage is present at primary side of low voltage transformer.	Low voltage transformer or secondary circuit defective. Check and replace control unit.

8) Disconnect the power supply cord and then remove outer case.

9) Open the door and block it open.

10) Discharge high voltage capacitor.

11) Reconnect all leads removed from components during testing.

12) Re-install the outer case (cabinet).

13) Reconnect the power supply cord after the outer case is installed.

14) Run the oven and check all functions.

CHAPTER 9. TOUCH CONTROL PANEL ASSEMBLY

[1] OUTLINE OF TOUCH CONTROL PANEL

The touch control section consists of the following units as shown in the touch control panel circuit.

- (1) Key Unit (2) Control Unit

The principal functions of these units and their related signals are explained below.

1. Control Unit

Signal of key touch and oven function control are all processed by one microcomputer.

- 1) Power Supply Circuit

This circuit changes output voltage at the secondary side of the low voltage (T1) transformer to voltages required at each part by full wave rectifying circuit, constant voltage circuit, etc..

- 2) ACL Circuit

This is an Auto-clear Circuit, i.e., a reset circuit, which enables IC1 to be activated from initial state.

- 3) Power SYNC Signal Generating Circuit

This is a circuit for generating power SYNC signal by virtue of the secondary side output of transformer T1. This signal is used for a basic frequency to time processing and so on.

- 4) Clock Circuit

This is a circuit for controlling clock frequency required for operating IC1.

- 5) IC1 (Main Processor)

This is a one-chip microcomputer, responsible for controlling the entire control unit.

- 6) IC2 (Memory Processor)

This is a memory IC, responsible for memory function.

- 7) IC3

This is a IC for driving light emitting diode.

- 8) Display Circuit

This is a circuit for driving light emitting diode by IC1 output.

- 9) Key Input Circuit

This is a circuit for transmitting key input information to IC1.

- 10) Sound-body Driving Circuit

This is a circuit for driving sound body by IC1 output.

- 11) Relay Driving Circuit

This is a circuit for driving output relay by IC1 output.

- 12) Door Sensing Switch Circuit

This is a circuit for driving IC1 to detect door opening/ closing.

2. Key Unit

The key unit is composed of a matrix circuit in which when a key is touched, one of signals P30--P34 generated by the LSI, is passed through the key and returned to the LSI as one of signals P24--P27. This model has 20 Memory pads. When the oven is shipped, Memory pad 1 to 10 are set as follows: fig.1.

Memory No.	Cook Time	Output Power
1	10 sec.	100%
2	20 sec.	100%
3	30 sec.	100%
4	45 sec.	100%
5	1 min.	100%
6	1 min. 15 sec.	100%
7	1 min. 30 sec.	100%
8	2 min.	100%
9	2 min. 30 sec.	100%
0	3 min.	100%

(fig. 1)

This model has a double quantity pad. When the oven is shipped, Magnification "1.7" is preset in the double quantity pad. This model has an express defrost pad. When the oven is shipped, express defrost is set as follows: fig.2.

	1 STAGE	2 STAGE	3 STAGE
FORMULA	P = 0.2T	P = 0.15T	P = 0.65T
POWER	0.6	0.4	0.2

T : Total cooling time

(fig. 2)

When 1/2 total cooking time is passed, the signal will sound and "CHECK" indicator will flash.

[2] SERVICING FOR TOUCH CONTROL PANEL

1. Precautions for Handling Electronic Components

This unit uses CMOS LSI in the integral part of the circuits. When handling these parts, the following precautions should be strictly followed. CMOS LSI have extremely high impedance at its input and output terminals. For this reason, it is easily influenced by the surrounding high voltage power source, static electricity charge in clothes, etc., and sometimes it is not fully protected by the built-in protection circuit.

In order to protect CMOS LSI.

- 1) When storing and transporting, thoroughly wrap them in aluminium foil. Also wrap PW boards containing them in aluminium foil.
- 2) When soldering, ground the technician as shown in the figure and use grounded soldering iron and work table.

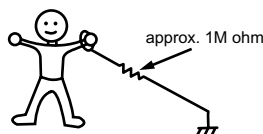

2. Servicing of Touch Control Panel

We describe the procedures to permit servicing of the touch control panel of the microwave oven and the precautions you must take when doing so. To perform the servicing, power to the touch control panel is available either from the power line of the oven itself or from an external power source.

1. Servicing the touch control panel with power supply of the oven:

CAUTION: THE HIGH VOLTAGE TRANSFORMER OF THE MICROWAVE OVEN IS STILL LIVE DURING SERVICING AND PRESENTS A HAZARD.

Therefore, before checking the performance of the touch control panel,

- 1) Disconnect the power supply cord and then remove outer case.
- 2) Open the door and block it open.
- 3) Discharge high voltage capacitor.
- 4) Disconnect the leads to the primary of the power transformer.

- 5) Ensure that these leads remain isolated from other components and oven chassis by using insulation tape.
 - 6) After that procedure, re-connect the power supply cord.
- After checking the performance of the touch control panel,
- 1) Disconnect the power supply cord.
 - 2) Open the door and block it open.
 - 3) Re-connect the leads to the primary of the power transformer.
 - 4) Re-install the outer case (cabinet).
 - 5) Re-connect the power supply cord after the outer case is installed.
 - 6) Run the oven and check all functions.

- a) On some models, the power supply cord between the touch control panel and the oven itself is so short that the two can't be separated. For those models, check and repair all the controls (sensor-related ones included) of the touch control panel while keeping it connected to the oven.
- b) On some models, the power supply cord between the touch control panel and the oven proper is so long enough that they may be separated from each other. For those models, therefore, it is possible to check and repair the controls of the touch control panel while keeping it apart from the oven proper; in this case you must short both ends of the door sensing switch (on PWB) of the touch control panel with a jumper, which brings about an operational state that is equivalent to the oven door being closed. As for the sensor-related controls of the touch control panel, checking them is possible if the dummy resistor(s) with resistance equal to that of the controls are used.

2. Servicing the touch control panel with power supply from an external power source:

Disconnect the touch control panel completely from the oven proper, and short both ends of the door sensing switch (on PWB) of the touch control panel, which brings about an operational state that is equivalent to the oven door being closed. Connect an external power source to the power input terminal of the touch control panel, then it is possible to check and repair the controls of the touch control panel; it is also possible to check the sensor-related controls of the touch control panel by using the dummy resistor(s).

3. Servicing Tools

Tools required to service the touch control panel assembly.

- 1) Soldering iron: 60W
(It is recommended to use a soldering iron with a grounding terminal.)
- 2) Oscilloscope: Single beam, frequency range: DC - 10MHz type or more advanced model.
- 3) Others: Hand tools

4. Other Precautions

- 1) Before turning on the power source of the control unit, remove the aluminium foil applied for preventing static electricity.
- 2) Connect the connector of the key unit to the control unit being sure that the lead wires are not twisted.
- 3) After aluminium foil is removed, be careful that abnormal voltage due to static electricity etc. is not applied to the input or output terminals.
- 4) Attach connectors, electrolytic capacitors, etc. to PWB, making sure that all connections are tight.
- 5) Be sure to use specified components where high precision is required.

[3] PROCEDURE FOR CHECKING/CLEARING SERVICE COUNTS OF MICROWAVE OVEN

The following procedure enables the servicer to obtain the total using times (cook cycles) since the microwave oven is purchased and the total operation time (hours) since the microwave oven is purchased. The maximum capacity of the total using is 999,999 times, and the maximum capacity of total operation time is 999,999 hours.

1. Practice for checking total using times (Ex. 345678 times).

■ ... Flashing / ○.. 0.1sec BUZZER

PAD	DISPLAY	INDICATOR	PHONE
(Door close)	.		
CHECK	.	CHECK No.	○
CHECK	#1 82 68 (user total count)	CHECK	○
#2			
SIGNAL	↓		
SIGNAL			
DOUBLE QUANTITY	34 56 (service total count upper figure) 3456XX		○
1 (No 1)	↓ 1	No.	○
(after 1 sec.)	↓ 34 56 (service total count upper figure)		
2 (No 2)	↓ 2	No.	○
(after 1 sec.)	↓ 78 (service total count lower figure)		
CHECK	.		○

2. Practice for checking total operation time (Ex. 4567 hours).

■ ... Flashing / ○.. 0.1sec BUZZER

PAD	DISPLAY	INDICATOR	PHONE
(Door close)	.		
CHECK	.	CHECK No.	○
CHECK	#1 82 68 (user total count)	CHECK	○
#2			
SIGNAL	↓		
SIGNAL			
DOUBLE QUANTITY	34 56 (service total count upper figure) 3456XX		○
9 (No 9)	↓ 9	No.	○
(after 1 sec.)	↓ 45 (Total operation time upper figure)		
0 (No 0)	↓ 0	No.	○
(after 1 sec.)	↓ 67 (Total operation time lower figure)		
CHECK	.		○

#1 : No key entry signal.

#2 : To set -B, touch the selectapower key twice.

3. Practice for inputting total using times (Ex. 310000 times).

■... Flashing / ○.. 0.1sec BUZZER

PAD	DISPLAY	INDICATOR	PHONE
(Door close)	.		
CHECK	.	CHECK No.	○
CHECK	82 68 (user total count)	CHECK	○
#2 SIGNAL	↓		
SIGNAL	34 56 (service total count upper figure)		○
DOUBLE QUANTITY	3456XX		
2	2 ↓ 78 (service total count lower figure)	No.	○
(after 1 sec.)	XXXX78		
1	1 ↓ 34 56	No.	○
(after 1 sec.)	0		○
SET	0		○
3,1,0,0	31 00		○ x 4
SET	31 00		○
2	2 ↓ 78	No.	○
(after 1 sec.)	0		○
SET	0		○
0	0		○
SET	0		○
	(service total count 310000 set)		
CHECK	.		○

#1 : No key entry signal.

#2 : To set -B, touch the selectapower key twice.

4. Practice for inputting total operation time (Ex. 1234 hours).

■... Flashing / ○... 0.1sec BUZZER

PAD	DISPLAY	INDICATOR	PHONE
(Door close)	.		
CHECK	.	CHECK No.	○
CHECK	82 68 (user total count)	CHECK	○
#2 SIGNAL	↓		
SIGNAL	34 56 (service total count upper figure)		○
DOUBLE QUANTITY	3456XX		
9	9 ↓ 45	No.	○
(after 1 sec.)	0		○
SET	0		○
1,2	12		○ x 2
SET	12		○
0	1 0 ↓ 67	No.	○
(after 1 sec.)	0		○
SET	0		○
3,4	34		○ x 2
SET	34		○
	(Total operation time 1234 hours set)		
CHECK	.		○

5. Practice for cancelling total using times and total operation time (user and service) and all other counter.

■... Flashing / ○... 0.1sec BUZZER

PAD	DISPLAY	INDICATOR	PHONE
(Door close)	.		
SET	.		
SET	.	No.	○
(within 2.0sec.)	.		
DOUBLE QUANTITY	.	DOUBLE	○
CHECK	.		
SINGLE	.		
SET	.		○

[4] OTHER SETTING AND CHECKING PROCEDURE

1. EXPRESS DEFROST

T = STG1 + STG 2 + STG3

STG = A x T + B

1) To set the constants of Express defrost.

(Ex. 020T, 60% at 1st stage / 0.15T, 40% at 2nd stage/ 0.65T, 20% at 3rd stage)

" " : Flicker / ○: 0.1 sec BUZZER

PAD ORDER	DISPLAY	PHONE
(Door close)	.	
SET	.	
SET	"NO"	○
(within 2 sec.)	.	
#1 START	.	
EXPRESS DEF	0.00 DEF.	○
2,0	0.20 DEF	○ x 2
	(A)	
#2 SELECTATIME	0 DEF	○
0	0 DEF	○
	(+ - B)	
	DEF	○
#4 SELECTAPOW	P -	○
6	P - 60	○
SELECTATIME	0.00 DEF	○
1,5	0.15 DEF	○ x 2
	(A)	
SELECTATIME	0 DEF	○
0	0 DEF	○
	(+ - B)	
	DEF	○
#4 SELECTAPOW	P -	○
4	DEF - 40	○
SELECTATIME	0 DEF	○
#3 5	5 DEF	○
	DEF	○
#4 SELECTAPOW	P -	○
2	DEF - 20	○
SET	. DEF	○
SET	.	○

#1 : No key entry signal.

#2 : To set -B, touch the selectapower key twice.

#3 : Ex. defrost is paused after 50% of cooking time has lapsed when 5 key is entered, otherwise it is paused at the end of each stage.

#4 : For R-21LTF, change selectapower key to signal key.

KEY	DISPLAY	PAUSE
0	0	End of each stage
1	1	After 10% of total cooking time is passed
:	:	:
9	9	After 90% of total cooking time is passed
START	A	There is no pause

2) To check the constants of Express defrost.

" ": Flicker / ○: 0.1 sec BUZZER

PAD	DISPLAY	INDICATOR	PHONE
	.		○
CHECK	.	"No." CHECK	○
EXPRESS DEFROST	0.20 (A) 0 (+B) ↓ P 60 (PL) ↓ 0.15 (A) 0 (+B) ↓ P - 40 (PL) ↓ 5 (pause time) ↓ P - 20 (PL) ↓ (repeat)	DEF	
CHECK	.		○

3) To set user counts

Practice for inputting total number of using times (Ex. 3100 times), and using times of Memory 1 (Ex. 100 times).

" ": Flicker / ○: 0.1 sec BUZZER

PAD	DISPLAY	INDICATOR	PHONE
(Door close)	.		
	.		
CHECK	.	CHECK No.	○
CHECK	82 68 (user total count)	CHECK	○
DOUBLE QUANTITY SIGNAL	↓		○
SET	0		○
3,1,0,0	31 00		○ x 4
SET	31 00 (user total count 3100 set)		○
#A 1	↓ 1	No.	○
(after 1 sec.)	1 32 (memory 1 count)		
SET	0		○
1,0,0	1 00		○ x 3
SET	1 00 (memory 1 count 100 set)		○
CHECK	↓ .		○

NOTE: 1) To input using times of other memory, touch necessary Memory key at above step #A.

2) To input using times of manual cooking, touch SELECTA-TIME key at above step #A.

3) o input using times of Express Defrost, touch EXPRESS DEFROST key at above step #A.

CHAPTER 10. PRECAUTIONS FOR USING LEAD-FREE SOLDER

[1] Employing lead-free solder

The "Main PWB" of this model employs lead-free solder. This is indicated by the "LF" symbol printed on the PWB and in the service manual. The suffix letter indicates the alloy type of the solder.

Example:



Indicates lead-free solder of tin, silver and copper

[2] Using lead-free wire solder

When repairing a PWB with the "LF" symbol, only lead-free solder should be used. (Using normal tin/lead alloy solder may result in cold soldered joints and damage to printed patterns.)

As the melting point of lead-free solder is approximately 40°C higher than tin/lead alloy solder, it is recommended that a dedicated bit is used, and that the iron temperature is adjusted accordingly.

[3] Soldering

As the melting point of lead-free solder (Sn-Ag-Cu) is higher and has poorer wettability, (flow), to prevent damage to the land of the PWB, extreme care should be taken not to leave the bit in contact with the PWB for an extended period of time. Remove the bit as soon as a good flow is achieved. The high content of tin in lead free solder will cause premature corrosion of the bit. To reduce wear on the bit, reduce the temperature or turn off the iron when it is not required.

Leaving different types of solder on the bit will cause contamination of the different alloys, which will alter their characteristics, making good soldering more difficult. It will be necessary to clean and replace bits more often when using lead-free solder. To reduce bit wear, care should be taken to clean the bit thoroughly after each use.

CHAPTER 11. COMPONENT REPLACEMENT AND ADJUSTMENT PROCEDURE

[1] WARNING

WARNING AGAINST HIGH VOLTAGE:

Microwave ovens contain circuitry capable of producing very high voltage and current, contact with following parts may result in severe, possibly fatal, electric shock.

(Example)

High Voltage Capacitor, Power Transformer, Magnetron, High Voltage Rectifier Assembly, High Voltage Harness etc..

WARNING: Avoid possible exposure to microwave energy. Please follow the instructions below before operating the oven.

- | | |
|--|---|
| <ol style="list-style-type: none"> 1. Disconnect the power supply cord. 2. Visually check the door and cavity face plate for damage (dents, cracks, signs of arcing etc.). <p>Carry out any remedial work that is necessary before operating the oven.</p> <p>Do not operate the oven if any of the following conditions exist:</p> <ol style="list-style-type: none"> 1. Door does not close firmly. 2. Door hinge, support or latch hook is damaged. 3. The door gasket or seal is damaged. 4. The door is bent or warped. | <ol style="list-style-type: none"> 5. There are defective parts in the door interlock system. 6. There are defective parts in the microwave generating and transmission assembly. 7. There is visible damage to the oven. <p>Do not operate the oven:</p> <ol style="list-style-type: none"> 1. Without the RF gasket (Magnetron). 2. If the wave guide or oven cavity are not intact. 3. If the door is not closed. 4. If the outer case (cabinet) is not fitted. |
|--|---|

WARNING FOR WIRING

To prevent an electric shock, take the following precautions.

- | | |
|--|--|
| <ol style="list-style-type: none"> 1. Before wiring, <ol style="list-style-type: none"> 1) Disconnect the power supply cord. 2) Open the door block it open. 3) Discharge the high voltage capacitor and wait for 60 seconds. 2. Don't let the wire leads touch to the following parts: <ol style="list-style-type: none"> 1) High voltage parts: Magnetron, High voltage transformer, High voltage capacitor and High voltage rectifier assembly. 2) Hot parts: Oven lamp, Magnetron, Power transformer and Oven cavity. | <ol style="list-style-type: none"> 3) Sharp edge: Bottom plate, Oven cavity, Waveguide flange Chassis support and other metallic plate. 4) Movable parts (to prevent a fault) Fan blade, Fan motor, Switch, Switch lever, and Antenna motor 3. Do not catch the wire leads in the outer case cabinet. 4. Insert the positive lock connector until its pin is locked and make sure that the wire leads do not come off even if the wire leads are pulled. 5. To prevent an error function, connect the wire leads correctly, referring to the Pictorial Diagram. |
|--|--|

Please refer to "OVEN PARTS, CABINET PARTS, CONTROL PANEL PARTS, DOOR PARTS", when carrying out any of the following removal procedures:

[2] OUTER CASE REMOVAL

To remove the outer case, procedure as follows.

1. Disconnect the power supply cord.
2. Open the oven door and block it open.
3. Remove the five (5) screws from rear and along the side edge of case.
4. Slide the entire case back about 3cm to free it from retaining clips on the cavity face plate.
5. Lift entire outer case from the unit.
6. Discharge the H.V. capacitor before carrying out any further work.
7. Do not operate the oven with the outer case removed.

CAUTION: DISCONNECT OVEN FROM POWER SUPPLY BEFORE REMOVING OUTER CASE.

DISCHARGE THE HIGH VOLTAGE CAPACITOR BEFORE TOUCHING ANY OVEN COMPONENTS OR WIRING.

[3] POWER TRANSFORMER REMOVAL

1. Disconnect the power supply cord and remove outer case.
2. Open the oven door and block it open.
3. Discharge high voltage capacitor.
4. Disconnect the filament leads of power transformer from high voltage capacitor and the magnetron.
5. Disconnect the H.V. wire from the power transformer.
6. Disconnect the main wire harness from the power transformer.
7. Remove the two (2) screws and two (2) VCP caps holding the transformer to base plate.
8. Remove the transformer.
9. Now the power transformer is free.

[4] HIGH VOLTAGE RECTIFIER ASSEMBLY AND HIGH VOLTAGE CAPACITOR REMOVAL

To remove the components, proceed as follows.

1. Disconnect the power supply cord and remove outer case.
2. Open the oven door and block it open.
3. Discharge high voltage capacitor.
4. Disconnect H.V. wire of the high voltage rectifier assembly from the magnetron and the power transformer.
5. Disconnect the filament lead of the power transformer from the high voltage capacitor.
6. Remove one (1) screw holding earth side terminal of the high voltage rectifier assembly.
7. Disconnect all the leads and terminals of high voltage rectifier assembly from the high voltage capacitor.
8. Now, the high voltage rectifier assembly should be free.
9. Remove one (1) screw holding the capacitor holder to the oven cavity rear plate.
10. Remove one (1) screw holding the fan duct to the oven cavity rear plate.
11. Release the capacitor holder from the fan duct.
12. Remove the capacitor from the capacitor holder.
13. Now, the capacitor should be free.

CAUTION: WHEN REPLACING HIGH VOLTAGE RECTIFIER AND HIGH VOLTAGE CAPACITOR, GROUND SIDE TERMINAL OF THE HIGH VOLTAGE RECTIFIER MUST BE SECURED FIRMLY WITH A GROUNDING SCREW.

[5] MAGNETRON REMOVAL

1. Disconnect the power supply cord and remove outer case.
2. Open the oven door and block it open.
3. Discharge high voltage capacitor.
4. Disconnect the high voltage wire of the high voltage rectifier assembly and filament lead of the transformer from the magnetron.
5. Remove the one (1) screw holding the airguide to the magnetron and remove the airguide.
6. Remove the one (1) screw holding the insertion plate A to the magnetron and remove the insertion plate A.
7. Remove the one (1) screw holding the chassis support to the magnetron.
8. Release the tabs of air intake duct from the chassis support and the oven cavity.
9. Move the air intake duct to the left.
10. Carefully remove four (4) screws holding magnetron to waveguide, when removing the screws hold the magnetron to prevent it from falling.
11. Remove the magnetron from the waveguide with care so the magnetron antenna is not hit by any metal object around the antenna.

CAUTION: WHEN REPLACING THE MAGNETRON, BE SURE THE R.F. GASKET IS IN PLACE AND THE MAGNETRON MOUNTING SCREWS ARE TIGHTENED SECURELY.

[6] CONTROL PANEL ASSEMBLY REMOVAL**CONTROL PANEL ASSEMBLY**

1. Disconnect the power supply cord and remove outer case.
2. Open the door and block it open.
3. Discharge high voltage capacitor.
4. Disconnect the main wire harness from the control unit.
5. Remove the one (1) screw holding the control panel assembly to the oven cavity front plate.
6. Lift up the control panel assembly.
7. Now, the control panel assembly is free.

CONTROL UNIT

8. Disconnect the flat ribbon cable from the connector CN-G.
9. Remove the six (6) screws holding the control unit to the control panel frame.
10. Release the two (2) tabs of the control panel frame holding the control unit to the control panel frame.
11. Now, the control unit is free.

NOTE: 1) Before attaching a new key unit, wipe off remaining adhesive on the control panel frame surfaces completely with a soft cloth soaked in alcohol.

2) When attaching the key unit to the control panel frame, adjust the upper edge and right edge of the key unit to the correct position of control panel frame

3) Stick the key unit firmly to the control panel frame by rubbing with a soft cloth so not to cause scratches.

[7] OVEN LAMP AND LAMP SOCKET REMOVAL

1. Disconnect the power supply cord, and remove outer case.
2. Open the door and block it open.
3. Discharge high voltage capacitor.
4. Lift up the oven lamp socket from air intake duct.
5. Pull the wire leads from the oven lamp socket by pushing the terminal hole of the oven lamp socket with the small flat type screw driver.
6. Now, the oven lamp socket is free.

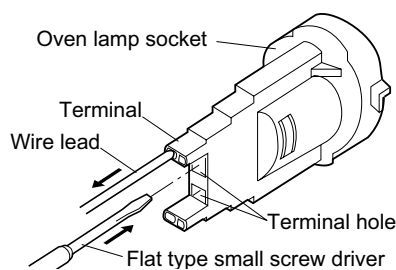

Figure C-1. Oven lamp socket

[8] POSITIVE LOCK CONNECTOR (NO-CASE TYPE) REMOVAL

1. Disconnect the power supply cord, and remove outer case.
2. Open the door and block it open.
3. Discharge high voltage capacitor.
4. Push the lever of positive lock® connector.
5. Pull down on the positive lock® connector.

CAUTION: WHEN CONNECTING THE POSITIVE LOCK® CONNECTORS TO THE TERMINALS, INSTALL THE POSITIVE LOCK® SO THAT THE LEVER FACES YOU.

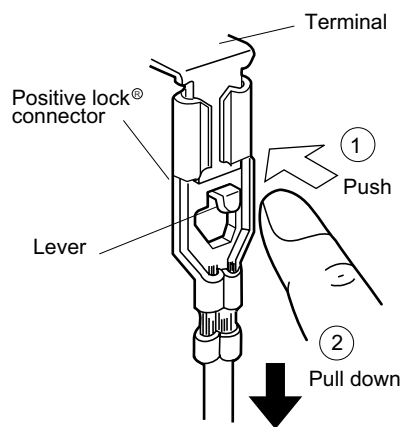

Figure C-1. Positive Lock® Connector

[9] ANTENNA MOTOR REMOVAL

1. Disconnect the power supply cord.
2. Remove the one (1) screw holding the base plate cover to the base plate and remove the base plate cover.

3. Disconnect the wire leads from the antenna motor and remove the one (1) screw holding the antenna motor.
4. Remove the antenna motor shaft from the antenna motor.
5. Now, the antenna motor is free.

[10] COOLING FAN MOTOR REMOVAL

1. REMOVAL

1. Disconnect the power supply cord and remove outer case.
2. Open the door and block it open.
3. Discharge high voltage capacitor.
4. Disconnect the wire leads from the fan motor.
5. Remove the one (1) screw holding the capacitor holder to the oven cavity rear plate.
6. Remove the one (1) screw holding the fan duct to the oven cavity rear plate.
7. Release the tabs of the capacitor holder from fan duct.
8. Remove the fan duct from the oven.
9. Remove the fan blade from the fan motor shaft according to the following procedure.
10. Hold the edge of the rotor of the fan motor by using a pair of groove joint pliers.

CAUTION: MAKE SURE THAT ANY PIECES DO NOT ENTER THE GAP BETWEEN THE ROTOR AND THE STATOR OF THE FAN MOTOR. BECAUSE THE ROTOR IS EASY TO BE SHAVEN BY PLIERS AND METAL PIECES MAY BE PRODUCED.

DO NOT TOUCH THE PLIERS TO THE COIL OF THE FAN MOTOR BECAUSE THE COIL MAY BE CUT OR INJURED.

DO NOT DISFIGURE THE BRACKET BY TOUCHING WITH THE PLIERS.

11. Remove the fan blade assembly from the shaft of the fan motor by pulling and rotating the fan blade with your hand.

12. Now, the fan blade will be free.

CAUTION: DO NOT RE-USE THE REMOVED FAN BLADE BECAUSE THE HOLE (FOR SHAFT) MAY BE LARGER THAN NORMAL.

13. Remove the two (2) screws holding the fan motor to the fan duct.
14. Now, the fan motor is free.

R21LTF

2. INSTALLATION

1. Install the fan motor to the fan duct with the two (2) screws.
2. Install the fan blade to the fan motor shaft according to the following procedure.
3. Hold the center of the bracket which supports the shaft of the fan motor on the flat table.
4. Install the fan blade to the shaft of fan motor by pushing the fan blade with a small, light weight, ball peen hammer or rubber mallet.

CAUTION: DO not hit the fan blade hard when installing because the bracket may be disfigured.

MAKE SURE THAT THE FAN BLADE ROTATES SMOOTH AFTER INSTALLED.

MAKE SURE THAT THE AXIS OF THE SHAFT IS NOT SLANTED.

5. Install the fan duct to the oven cavity rear plate with the one (1) screw.
6. Insert the tabs of the capacitor holder to the fan duct.
7. Install the capacitor holder to the oven cavity rear plate with the one (1) screw.
8. Re-connect the wire leads to the fan motor.

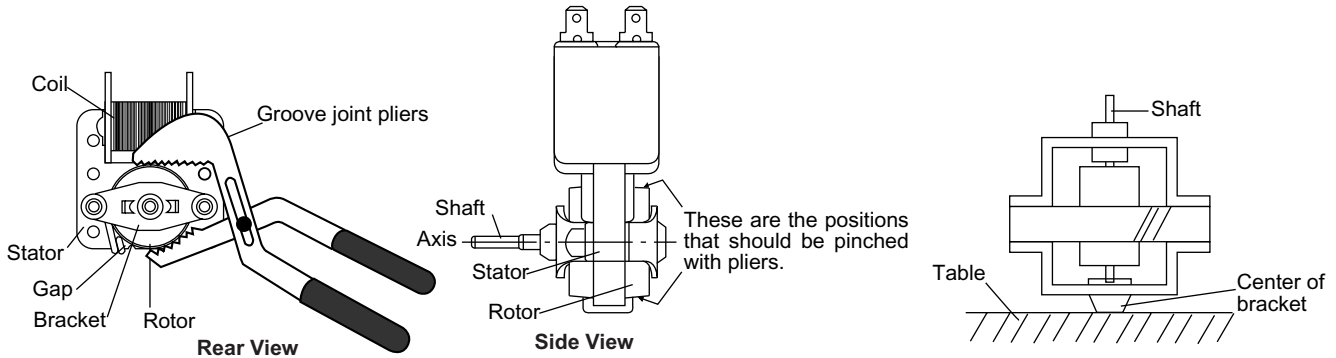

[11] POWER SUPPLY CORD REPLACEMENT

1. REMOVAL

1. Disconnect the power supply cord and then remove outer case.
2. Open the door and block it open.
3. Discharge high voltage capacitor.
4. Remove the one (1) screw holding the green wire to the cavity rear plate.
5. Disconnect the wire leads of the power supply cord from the noise filter.
6. Release the power supply cord from the oven cavity rear plate.
7. Now, the power supply cord is free.

2. REINSTALL

1. Insert the moulding cord stopper of power supply cord into the square hole of the oven cavity rear plate, referring to the Figure C-3b.
2. Install the earth wire lead of power supply cord to the cavity rear plate with one (1) screw and tighten the screw.
3. Connect the wire leads of power supply cord to the noise filter, referring to the Pictorial Diagram.

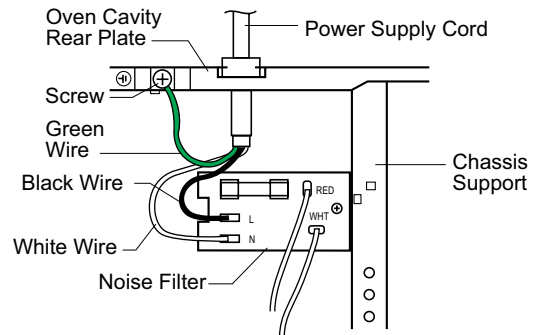

Figure C-3a. Power Supply Cord Replacement

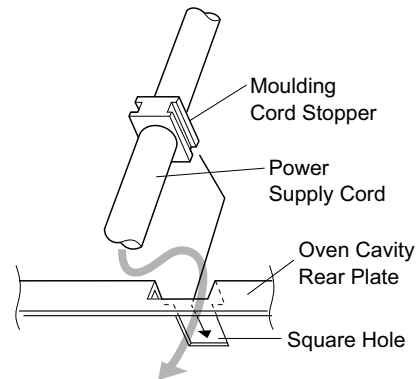

Figure C-3b. Power Supply Cord Replacement

[12] DOOR SENSING SWITCH/SECONDARY INTERLOCK SWITCH AND MONITOR SWITCH REMOVAL

1. REMOVAL

1. Disconnect the power supply cord and remove outer case.
2. Open the door and block it open.

3. Discharge high voltage capacitor.
4. Remove the control panel assembly, referring to section of CONTROL PANEL ASSEMBLY REMOVAL.

5. Disconnect the leads from all switches.
6. Remove the two (2) screws holding the latch hook to the oven cavity.
7. Remove the latch hook.
8. Push the retaining tab outward slightly and remove the switch.

2. REINSTALL

1. Re-install each switch in its place. The door sensing switch and monitor switch are in the lower position and the secondary interlock switch is in the upper position.
2. Re-connect wire leads to each switch. Refer to pictorial diagram.
3. Secure latch hook (with two (2) mounting screws) to oven flange.
4. Make sure that the monitor switch is operating properly and check continuity of the monitor circuit. Refer to chapter "Test Procedure" and Adjustment procedure.

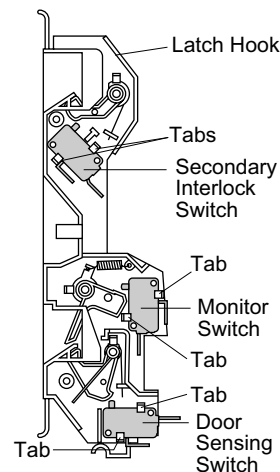

Figure C-4. Switches

[13] DOOR SENSING SWITCH/SECONDARY INTERLOCK SWITCH AND MONITOR SWITCH ADJUSTMENT

1. Adjustment

1. Disconnect the power supply cord, and then remove outer case.
2. Open the door and block it open.
3. Discharge high voltage capacitor.

If the door sensing switch, secondary interlock switch and monitor switch do not operate properly due to a misadjustment, the following adjustment should be made.

4. Loosen the two (2) screws holding latch hook to the oven cavity front flange.
5. With door closed, adjust latch hook by moving it back and forth, and up and down. In and out play of the door allowed by the upper and lower position of the latch hook should be less than 0.5mm. The vertical position of the latch hook should be adjusted so that the door sensing switch and secondary interlock switch are activated with the door closed. The horizontal position of the latch hook should be adjusted so that the plunger of the monitor switch is pressed with the door closed.
6. Secure the screws with washers firmly.
7. Check the operation of all switches. If each switch has not activated with the door closed, loosen screw and adjust the latch hook position.

2. After adjustment, check the following.

1. In and out play of door remains less than 0.5mm when in the latched position. First check upper position of latch hook, pushing and pulling upper portion of door toward the oven face. Then check lower portion of the latch hook, pushing and pulling lower portion of the door toward the oven face. Both results (play in the door) should be less than 0.5mm.

2. The door sensing switch and secondary interlock switch interrupt the circuit before the door can be opened.
3. Monitor switch contacts close when door is opened.
4. Re-install outer case and check for microwave leakage around door with an approved microwave survey meter. (Refer to Microwave Measurement Procedure.)

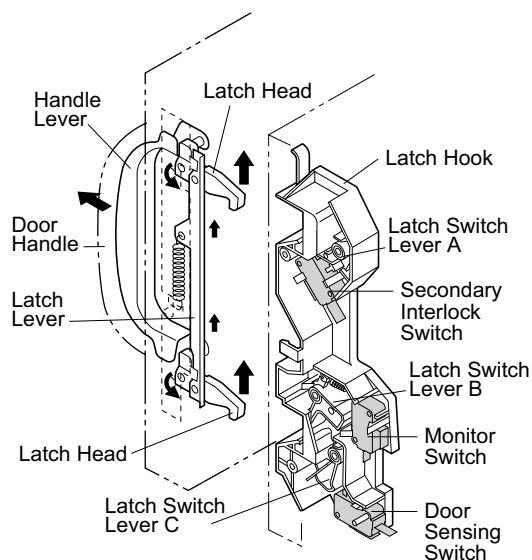

Figure C-5. Latch Switch Adjustments

[14] DOOR PARTS REMOVAL

1. REMOVAL

CHOKE COVER

1. Disconnect the power supply cord.
2. Open the door slightly.
3. Insert a putty knife (thickness of about 0.5mm) into the gap between the choke cover and door frame as shown in Figure C-6 to free engaging parts.

4. Pry the choke cover by inserting a putty knife as shown in Figure C-6.
5. Release choke cover from door panel.
6. Now choke cover is free.

NOTE: When carrying out any repair to the door, do not bend or warp the slit choke (tabs on the door panel assembly) to prevent microwave leakage.

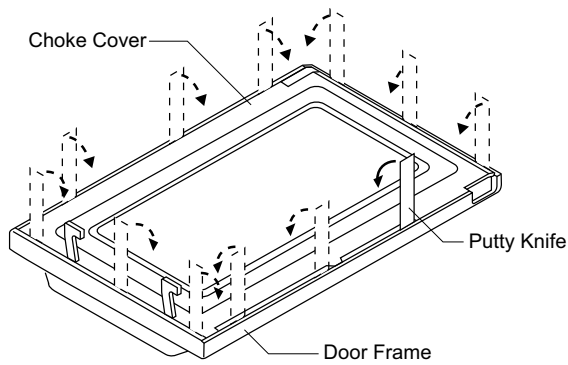

Figure C-6. Door Disassembly

7. Release two (2) pins of door panel from two (2) holes of upper and lower oven hinges by lifting up.
8. Remove the one (1) cushion (ferrite) from the lower opening between the door panel and the door frame.
9. Now, door sub assembly is free from oven cavity.

DOOR PANEL REMOVAL

10. Remove the four (4) screws holding the door panel to the door frame.
11. Release door panel from seven (7) tabs of door frame by sliding door panel downward.
12. Now, the door panel is free.

DOOR HANDLE REMOVAL

13. Release the latch spring from the tab of the latch angle assembly.
14. Remove the two (2) screws holding the door handle and the latch angle assembly through the door frame.
15. Now, door handle is free.

LATCH HEADS REMOVAL

16. Remove the one (1) screw holding the latch angle assembly to the door frame.
17. Remove the latch angle assembly together with the latch lever, latch spring and the upper and lower latch heads from the door frame.
18. Release the latch lever together with the latch spring and the latch heads from the latch angle assembly.
19. Release the two (2) latch heads from the latch lever.
20. Now, the upper and lower latch heads are free.

FRONT DOOR GLASS OR SEALER PLATE REMOVAL

(After DOOR PANEL REMOVAL)

- 1) Remove the four (4) screws holding the glass stopper U to the door frame and remove the glass stopper U.
- 2) Remove the two (2) screws holding the glass stopper R to the door frame and remove the glass stopper R.
- 3) Slide the front door glass and the sealer plate left at first and then slide upwards to release them from the tabs holding it.
- 4) Now, the front door glass or the sealer plate free.

DOOR CASE REMOVAL

(After DOOR PANEL REMOVAL)

- 1) Straighten all tabs of the door case holding the door case to the door frame.
- 2) Release door case from the door frame.

[15] ANTENNA MOTOR SHAFT REPLACEMENT

1. REMOVAL

1. Disconnect the power supply cord.

- 3) Now, the door case is free

NOTE: At this moment, the door badge is attached on the door case.

2. REINSTALL OF THE DOOR

1. Reinstall all door parts except the choke cover
2. Catch two (2) pins of door panel on two (2) holes of upper and lower oven hinges.
3. Insert the one (1) cushion (ferrite) into the lower opening between the door panel and the door frame.
4. Reinstall choke cover to door panel by pushing.

NOTE: **After any service to the door;**

- 1) **Make sure that door sensing switch, secondary interlock switch and monitor switch are operating properly. (Refer to chapter "Test Procedures").**
- 2) **An approved microwave survey meter should be used to assure compliance with proper microwave radiation emission limitation standards. (Refer to chapter "Test Procedures").**

3. After any service, make sure of the following:

1. Door latch heads smoothly catch latch hook through latch holes and that latch head goes through center of latch hole.
2. Deviation of door alignment from horizontal line of cavity face plate is to be less than 1.0mm.
3. Door is positioned with its face pressed toward cavity face plate.
4. Check for microwave leakage around door with an approved microwave survey meter. (Refer to Microwave Measurement Procedure.)

NOTE: **The door on a microwave oven is designed to act as an electronic seal preventing the leakage of microwave energy from oven cavity during cook cycle. This function does not require that door be air-tight, moisture (condensation)-tight or light-tight. Therefore, occasional appearance of moisture, light or sensing of gentle warm air movement around oven door is not abnormal and do not of themselves, indicate a leakage of microwave energy from oven cavity.**

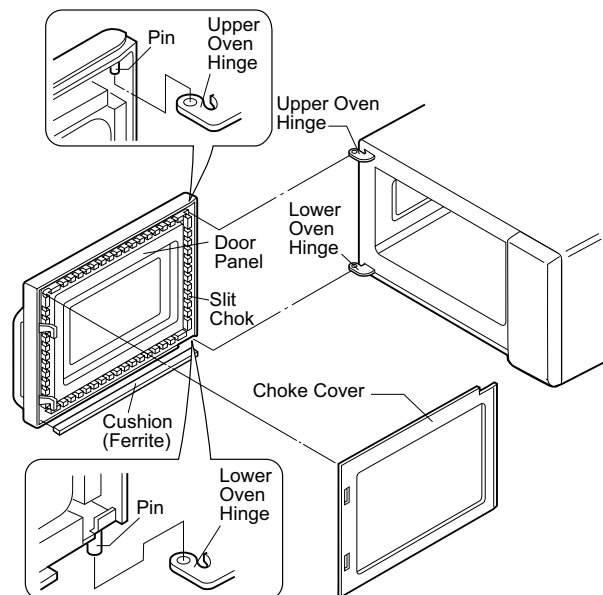

Figure C-7. Door Replacement

2. Open the door and block it open.

3. To discharge the high voltage capacitor, wait for 60 seconds.

4. Remove the antenna motor from the oven cavity bottom plate, referring to "ANTENNA MOTOR REMOVAL".
5. Remove the ceramic shelf from the oven cavity bottom plate.
6. Remove the one (1) screw and the one (1) washer holding the antenna holder of the stirrer antenna assembly to the oven cavity bottom plate through the square hole of the stirrer antenna. Refer to Figure C-8.
7. Release the antenna holder from the one (1) tab of the oven cavity bottom plate.
8. Remove the stirrer antenna assembly from the oven cavity bottom plate.
9. Remove the antenna motor shaft from the hole of the oven cavity bottom plate.
10. Now, the antenna motor shaft is free.

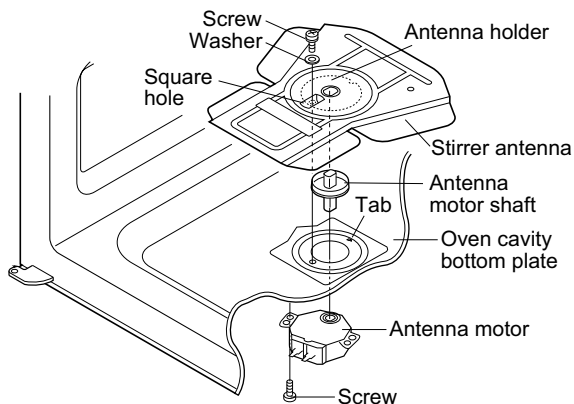

Figure C-8. Antenna Motor Shaft Removal

2. INSTALLATION

1. Install the antenna motor shaft into the hole of the oven cavity bottom plate, and turn the flat faces of antenna motor shaft to the left and right side walls of oven cavity (to fit the stirrer antenna holder). Refer to Figure C-9.

2. Set the direction of the stirrer antenna and antenna holder so that the hole of the antenna holder fit to the centre of the stirrer antenna's big blade. Refer to Figure C-9.
3. Hook the hole of the antenna holder on the tab of the oven cavity bottom plate. Refer to Figure C-10.
4. Insert the antenna holder into the hole of the oven cavity bottom plate and fit the hole of the antenna holder with an antenna motor shaft. Refer to Figure C-10.
5. Install the antenna holder to the oven cavity bottom plate with the one (1) screw and the one (1) washer. Refer to Figure C-8.
6. Install the antenna motor to the oven cavity bottom plate with one (1) screw. Refer to Figure C-8.
7. Connect the wire leads to the antenna motor, referring to the pictorial diagram.
8. Install the base plate cover to the base plate with one (1) screw.
9. Install the ceramic shelf to the oven cavity bottom plate. Refer to "INSTALLATION OF CERAMIC SHELF".

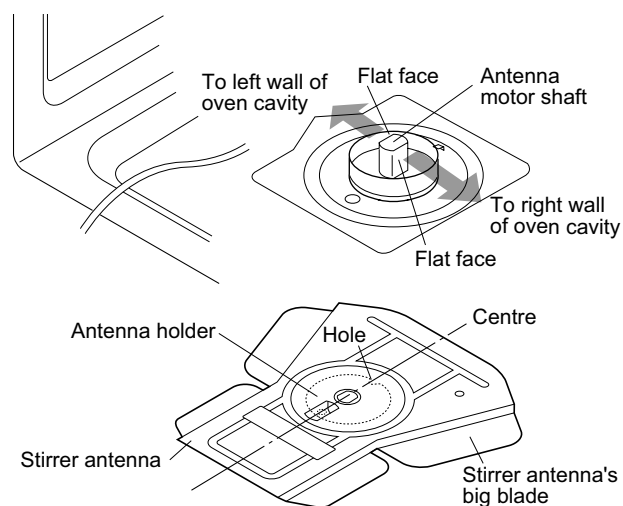

Figure C-9. Direction of Antenna Motor Shaft and Stirrer Antenna Assembly

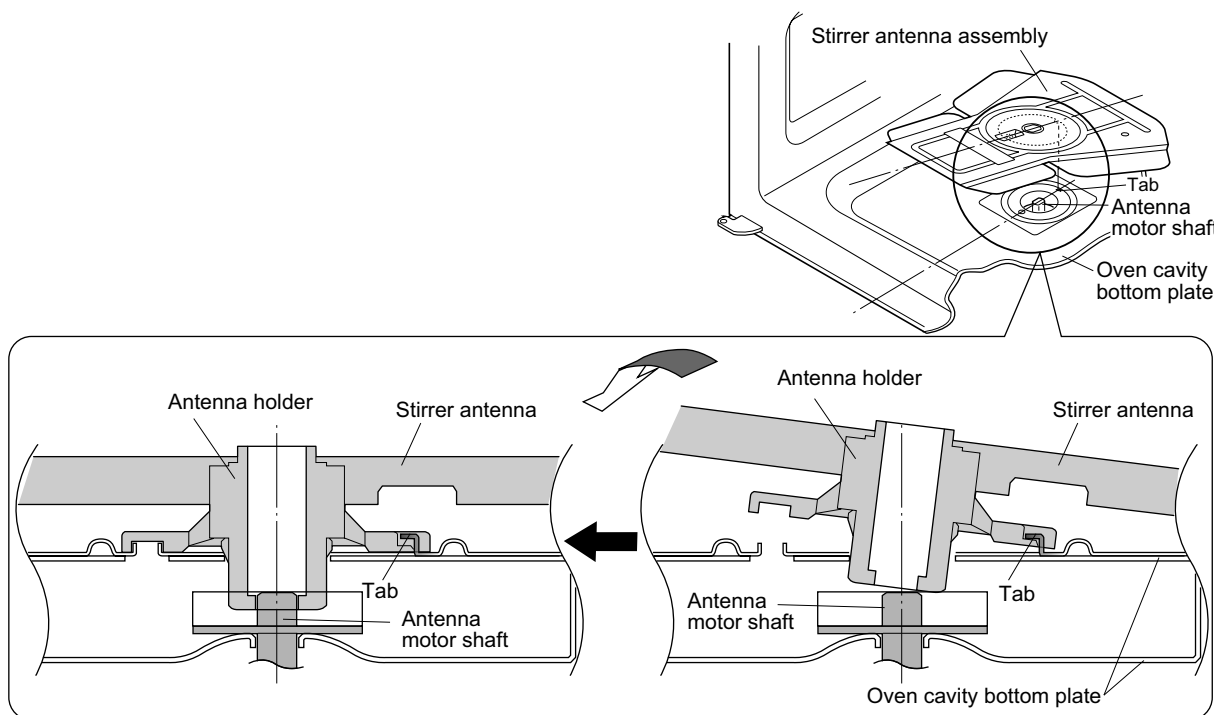

Figure C-10. Stirrer Antenna Assembly Installation

[16] INSTALLATION OF CERAMIC SHELF

1. Disconnect the power supply cord.
2. Open the door and block it open.
3. Make sure that the smooth surface of the ceramic shelf face up.
4. Make sure that the rubber packing without a fin of the ceramic shelf faces the front of the oven.

NOTE: The three (3) rubber packings with the fins and the one (1) rubber packing without a fin are attached to the four (4) edges of the ceramic shelf. The one (1) rubber packing without a fin is the front edge of the ceramic shelf.

5. Put the front edge of the ceramic shelf into the front edge of the oven cavity bottom plate.
6. Push down the rear edge of the ceramic shelf into the oven cavity bottom plate.
7. Now, the ceramic shelf is installed.

WARNING: Make sure that the rubber packing is not caught between the oven door and the oven cavity front plate, to avoid possible exposure to excessive microwave energy.

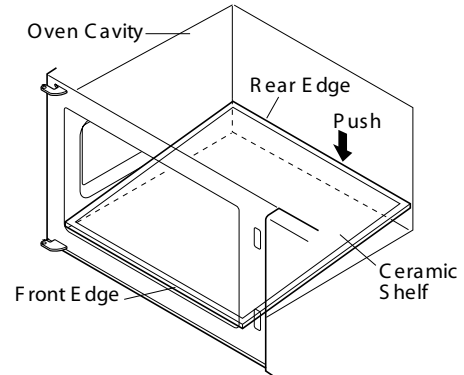

CHAPTER 12. CIRCUIT DIAGRAMS

[1] Pictorial Diagram (Figure S-1)

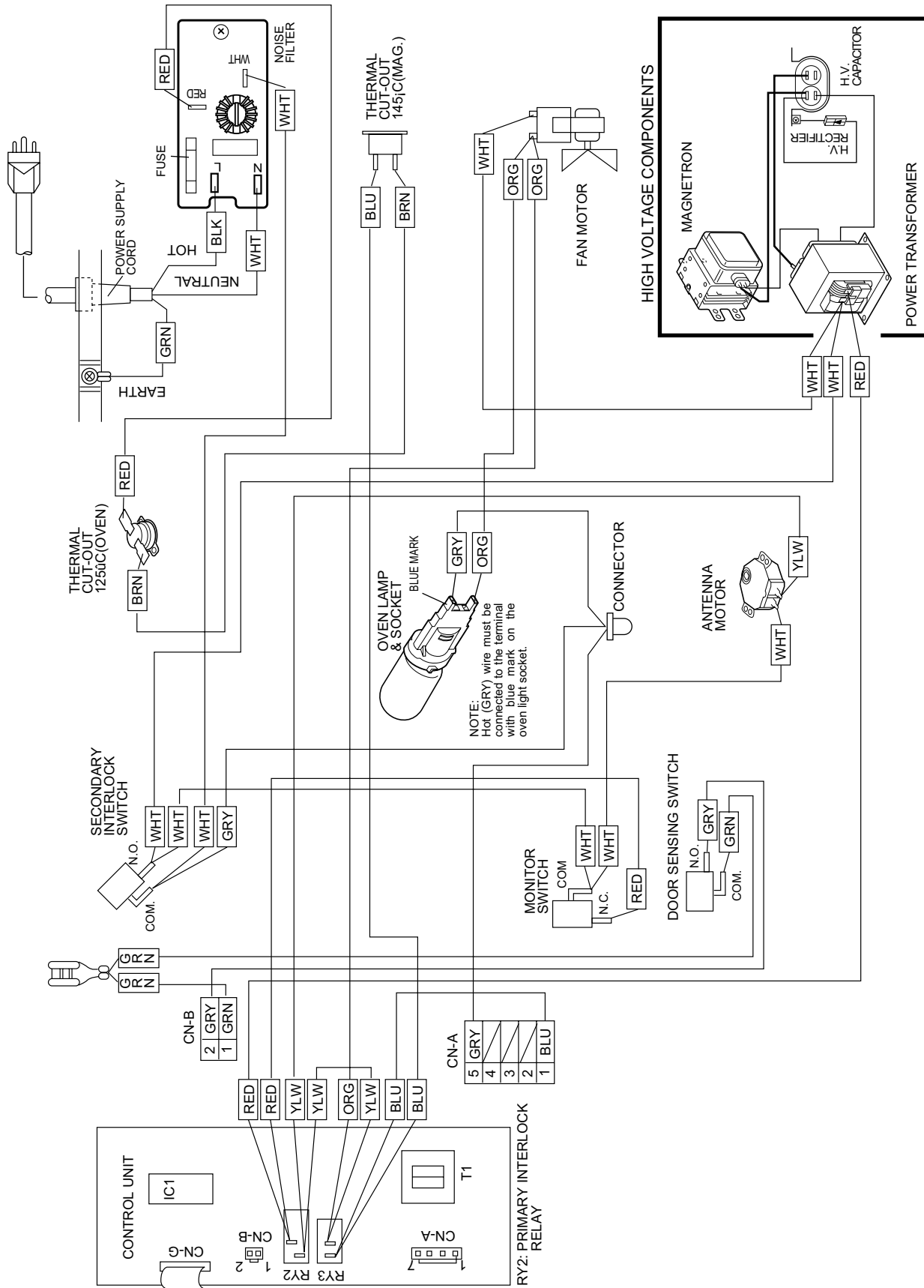

Figure S-1. Pictorial Diagram

[2] Control Panel Circuit (Figure S-2a and S-2b)

1. R21LTF

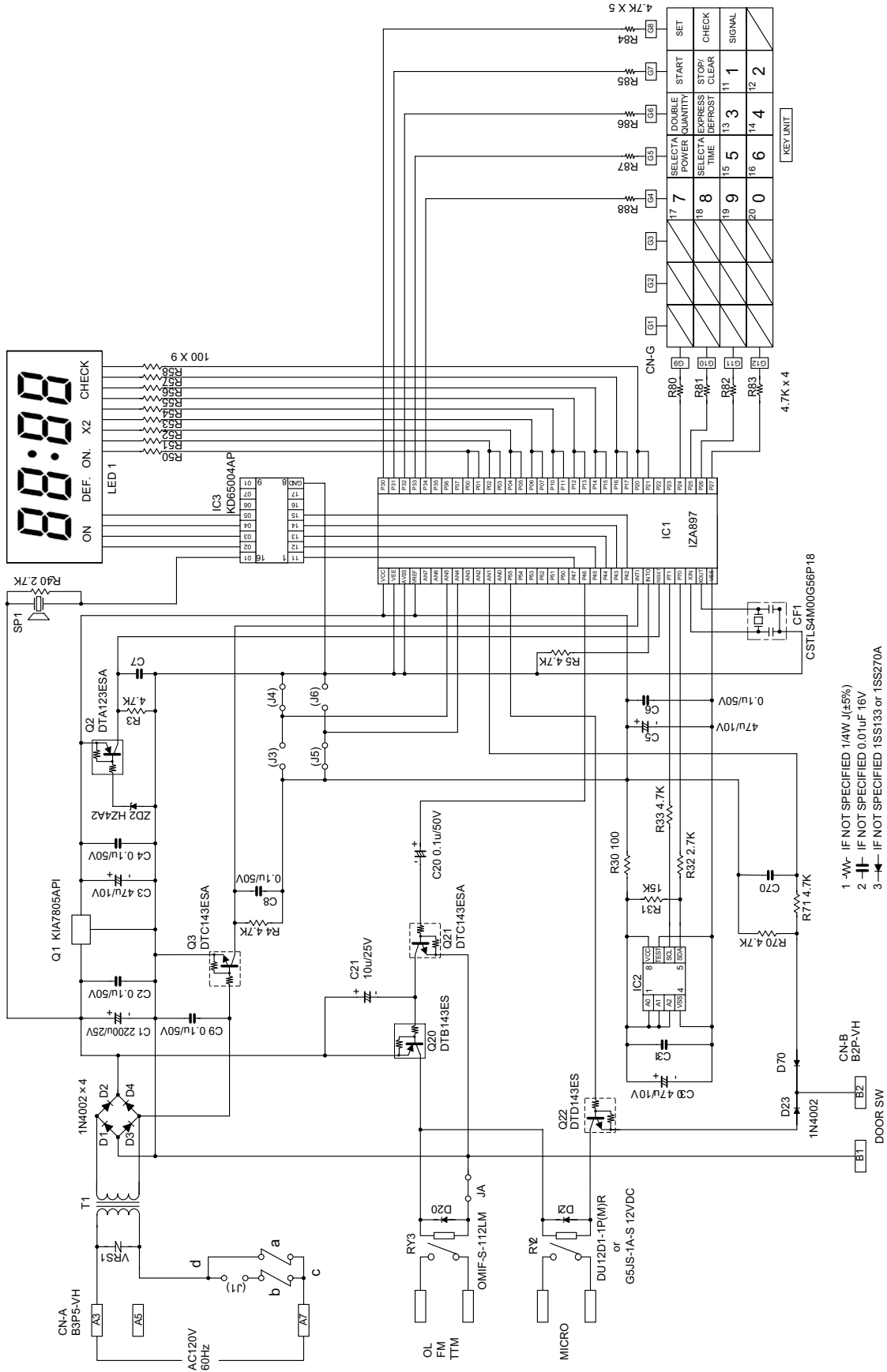

Figure S-2. Control Panel Circuit for R-21LTF

2. R-21LVF

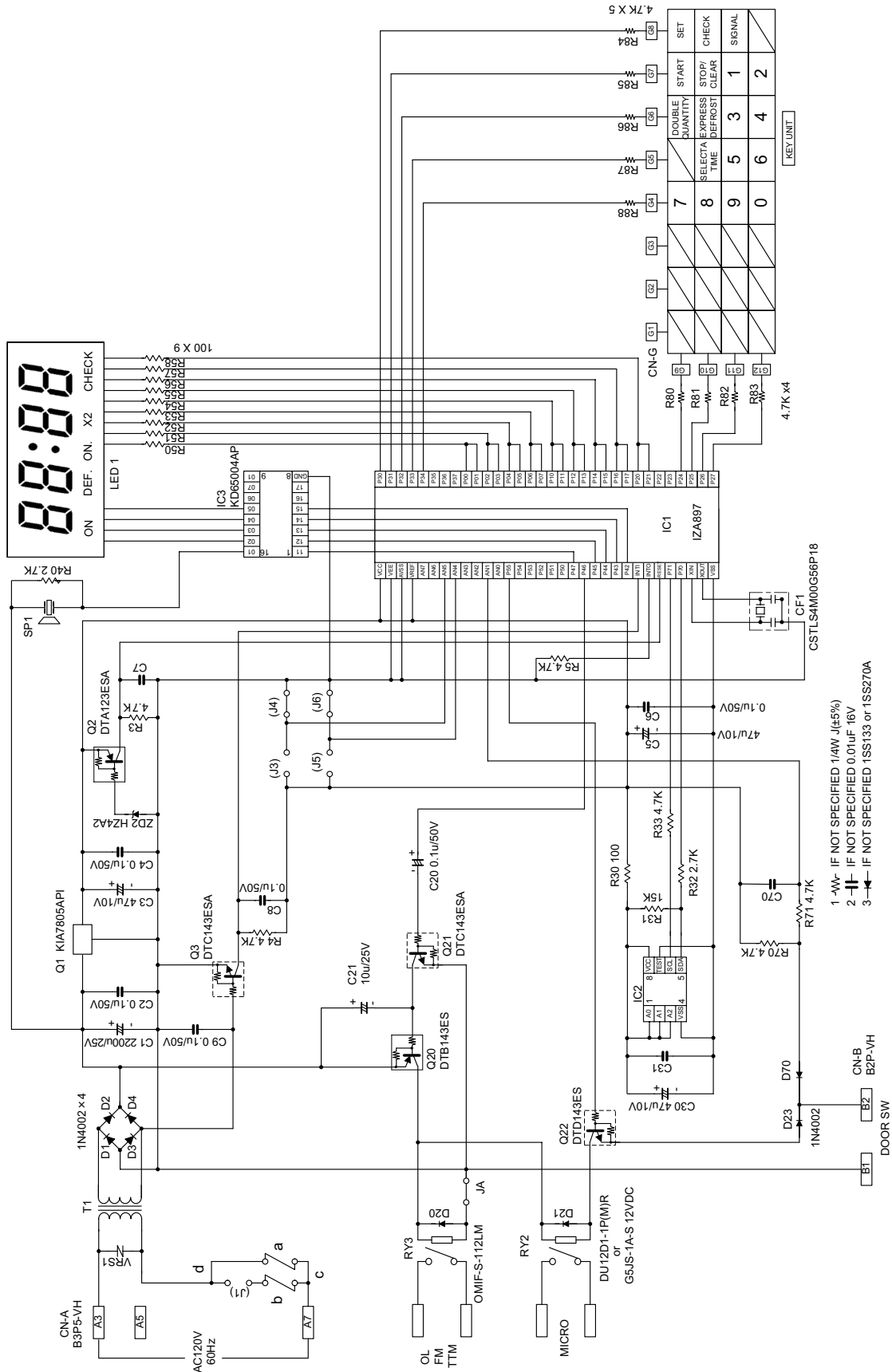

Figure S-2. Control Panel Circuit for R-21LVF

[3] Printed Wiring Board (Figure S-3)

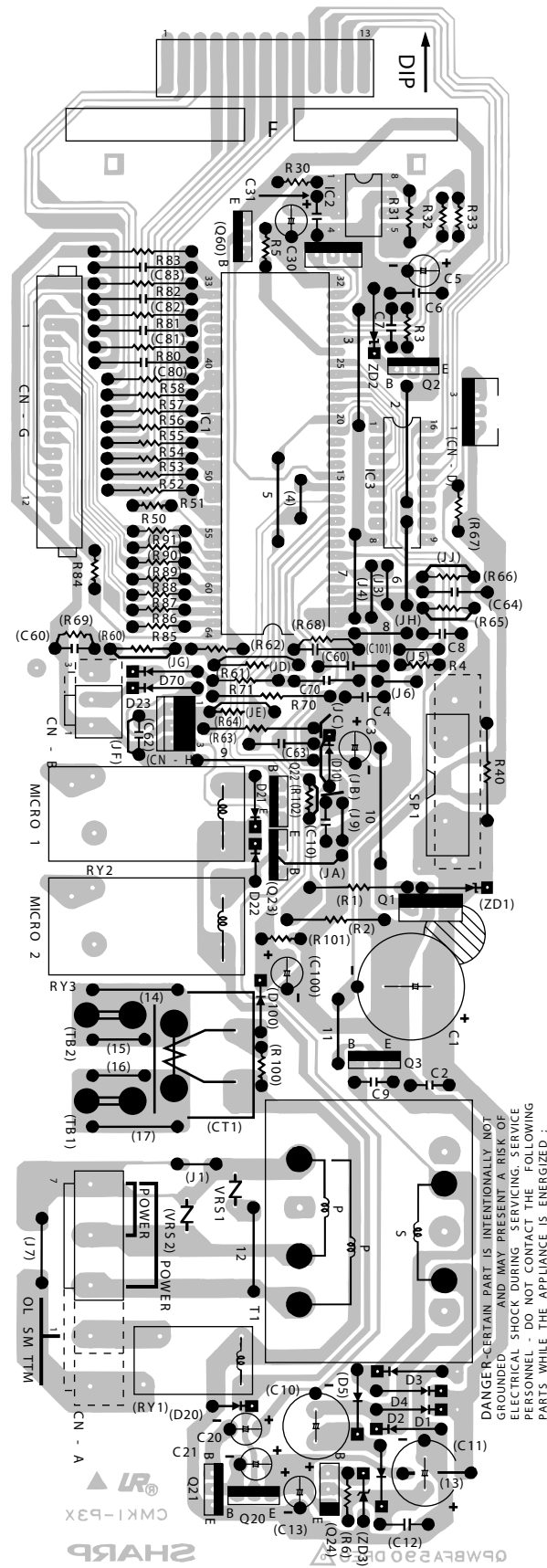

Figure S-3. Printed Wiring Board

SHARP PARTS LIST

HOW TO ORDER REPLACEMENT PARTS

To have your order filled promptly and correctly, please furnish the following information.

1. MODEL NUMBER
2. REF. NO.
3. PART NO.
4. DESCRIPTION

LIGHT DUTY COMMERCIAL MICROWAVE OVEN

MODELS R-21LTF R-21LVF

Parts marked "*" may cause undue microwave exposure.
Parts marked "▲" are used in voltage more than 250V.

CONTENTS

- | | |
|----------------------------|---------|
| [1] OVEN PARTS | PARTS |
| [2] DOOR AND CONTROL PANEL | ■ INDEX |

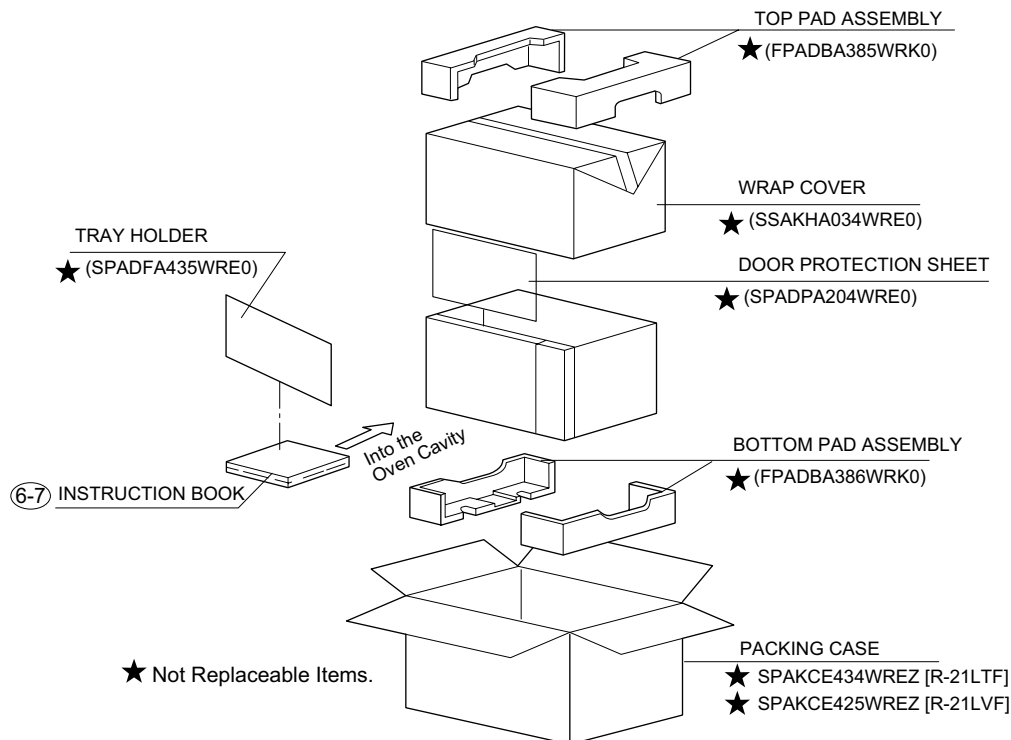

SHARP CORPORATION

This document has been published to be used for after sales service only.
The contents are subject to change without notice.

[1] OVEN PARTS

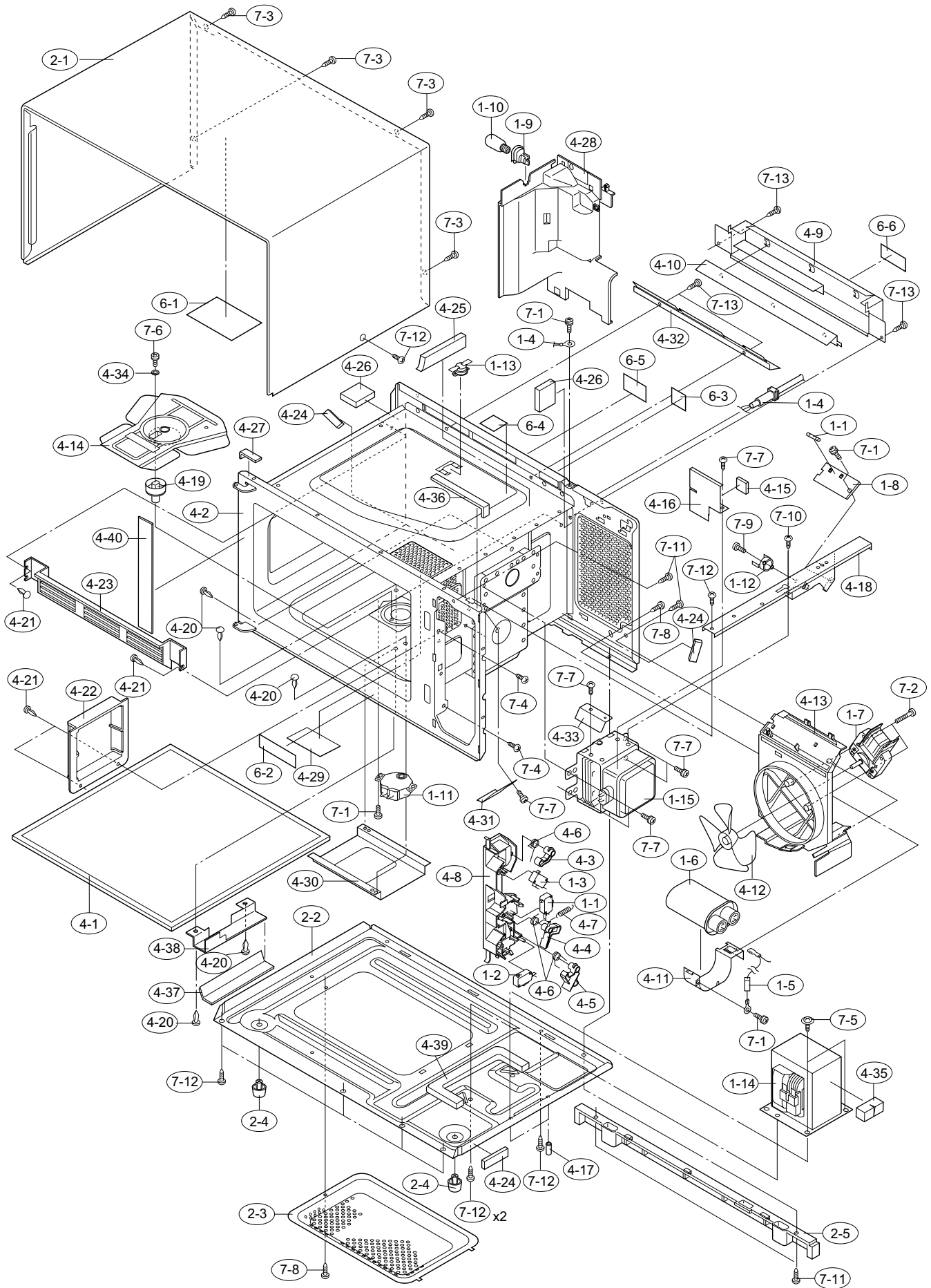

NO.	PARTS CODE	PRICE RANK	NEW MARK	PART RANK	DESCRIPTION	
[1] OVEN PARTS						
ELECTRIC PARTS						
1-1	FFS-BA033WRKZ	--			Monitor fuse20A and monitor switch (V-5220Q)	
1-2	QSW-MA085WRE0	AF			Door sensing switch	
1-3	QSW-MA135WRE0	AH			Secondary interlock switch	
1-4	FACCD A116WREZ	AV			Power supply cord	
△	1-5	FH-DZA119WRKZ	AU		High voltage rectifier assembly	
△	1-6	RC-QZA235WRE0	AU		High voltage capacitor	
△	1-6	RC-QZA336WRZZ	--		High voltage capacitor for production use (Interchangeable)	
	1-7	RMOTE A376WRE0	AU		Fan motor	
	1-8	FPWBFA389WRKZ	AW		Noise filter	
	1-8	FPWBFA417WRKZ	AY		Noise filter (Interchangeable)	
	1-9	QSOCLA021WRE0	AG		Oven lamp socket	
	1-10	RLMPTA086WRZZ	AL		Oven lamp	
	1-11	RMOTDA233WRE0	AQ		Antenna motor	
	1-12	RTHM-A138WRZZ	AH		Thermal cut-out 145 deg. (MAG)	
	1-12	RTHM-A080WRE0	AP		Thermal cut-out 145 deg. (MAG) (Interchangeable)	
	1-12	RTHM-A120WRE0	AH		Thermal cut-out 145 deg. (MAG) (Interchangeable)	
	1-13	RTHM-A137WRZZ	AH		Thermal cut-out 125 deg. (OVEN)	
	1-13	RTHM-A096WRE0	AK		Thermal cut-out 125 deg. (OVEN) (Interchangeable)	
	1-13	RTHM-A123WRZZ	AK		Thermal cut-out 123 deg. (OVEN) (Interchangeable)	
△	1-14	RTRN-A751WRZZ	BP		Power transformer	
△	1-15	RV-MZA347WRZZ	BH		Magnetron	
*	CABINET PARTS					
	2-1	GCABUA672WRP0	BH		Outer case cabinet	
	2-2	GDA i -A311WRW0	AS		Base plate	
	2-3	GCOVHA406WRW0	AQ		Base plate cover	
	2-4	GLEGPA074WRE0	AC		Foot	
	2-5	GLEGPA076WRF0	AF		Leg	
OVENPARTS						
	4-1	FGLSPA062WRE0	BL		Ceramic shelf	
*	4-2	*****	--		Oven cavity (Not a replaceable part)	
	4-3	MLEVPA227WRF0	AF		Latch switch lever A	
	4-4	MLEVPA228WRF0	AF		Latch switch lever B	
	4-5	MLEVPA229WRF0	AF		Latch switch lever C	
	4-6	MSPRCA108WRE0	AC		Latch lever spring	
	4-7	MSPRTA191WRE0	AC		Switch lever B spring	
*	4-8	PHOK-A160WRFZ	AN		Latch hook	
	4-9	FDUC-A341WRY0	BL		Steam duct sub assembly	
	4-10	PSKR-A351WRP0	AY		Steam guide	
	4-11	LBNDKA136WRP0	AQ		HV capacitor holder	
	4-12	NFANJA029WRE0	AK		Fan blade	
	4-13	PDUC-A888WRFZ	AM		Fan duct	
	4-14	FPLT-A007WRY0	BB		Stirrer antenna assembly	
	4-15	PCUSGA504WRP0	AB		Insertion cushion	
	4-16	PSKR-A348WRW0	AN		Insertion plate A	
	4-17	GCOVHA509WREZ	AG		VCP cap	
	4-18	LANGFA199WRWZ	AH		Chassis support	
	4-19	NSFTPA035WRFZ	AQ		Antenna motor shaft	
	4-20	PCL i CA032WRE0	AD		Hand clip 4	
	4-21	PCL i CA033WRE0	AD		Hand clip 5	
	4-22	PCOVPA344WRF0	AF		Side splash cover	
	4-23	PCOVPA345WRF0	AF		Back splash cover	
	4-24	PCUSGA249WRP0	AA		Cushion	
	4-25	PCUSUA511WRP0	AC		Cushion	
	4-26	PCUSUA194WRP0	AC		Cushion	
	4-27	PCUSUA514WRP0	AB		Cushion	
	4-28	PDUC-A966WRFZ	AT		Air intake duct	
	4-29	PF i LWA060WRP0	AD		Lamp filter	
	4-30	PSHEPA644WRE0	AD		Insertion sheet	
	4-31	PSKR-A347WRW0	AL		Insertion plate B	
	4-32	PSKR-A349WRP0	AF		Steam duct barrier	
	4-33	PSKR-A359WRW0	AM		Air guide	
	4-34	PSPA-A112WRE0	AC		Mica washer	
	4-35	PCUSGA378WRP0	AL		Cushion	
	4-36	PCUSUA507WRP0	AC		Cushion	
	4-37	PCUSUA517WRP0	AE		Cushion	
	4-38	PSHEPA674WRE0	AL		Cover	
	4-39	PCUSUA518WRP0	AC		Cushion	
	4-40	PSHEPA673WRE0	AD		S/Film	
MISCELLANEOUS						
	6-1	TMAPCA780WRRZ	AH		Schematic diagram	
	6-2	TCAUAA249WRR0	AE		Caution label	
	6-3	TCAUAA250WRR0	AF		DHHS caution label	
	6-4	TCAUAA295WRRZ	AH		Monitor caution	
	6-5	TCAUAA243WRR0	AC		Earth caution	

NO.	PARTS CODE	PRICE RANK	NEW MARK	PART RANK	DESCRIPTION
[1] OVEN PARTS					
6-6	TCAUAA245WRR0	AC			Cover caution
SCREWS, NUTS AND WASHERS					
7-1	XHPS740P08K00	AB			Screw : 4mm x 8mm
7-2	XEPS740P25000	AB			Screw : 4mm x 25mm
7-3	LX-CZA038WRE0	AA			Special screw
7-4	LX-CZ0052WRE0	AA			Special screw
7-5	LX-EZA042WRE0	AB			Special screw
7-6	XPWW40P04000	AB			Screw : 4mm x 4mm
7-7	XHPS740P08000	AB			Screw : 4mm x 8mm
7-8	XHTS740P08000	AC			Screw : 4mm x 8mm
7-9	XHPS730P06000	AB			Screw : 3mm x 6mm
7-10	XHTS740P08RV0	AG			Screw : 4mm x 8mm
7-11	XOTS740P12000	AA			Screw : 4mm x 12mm
7-12	XOTS740P08000	AA			Screw : 4mm x 8mm
7-13	XOTWW40P10000	AA			Screw : 4mm x 10mm

[2] DOOR AND CONTROL PANEL PARTS

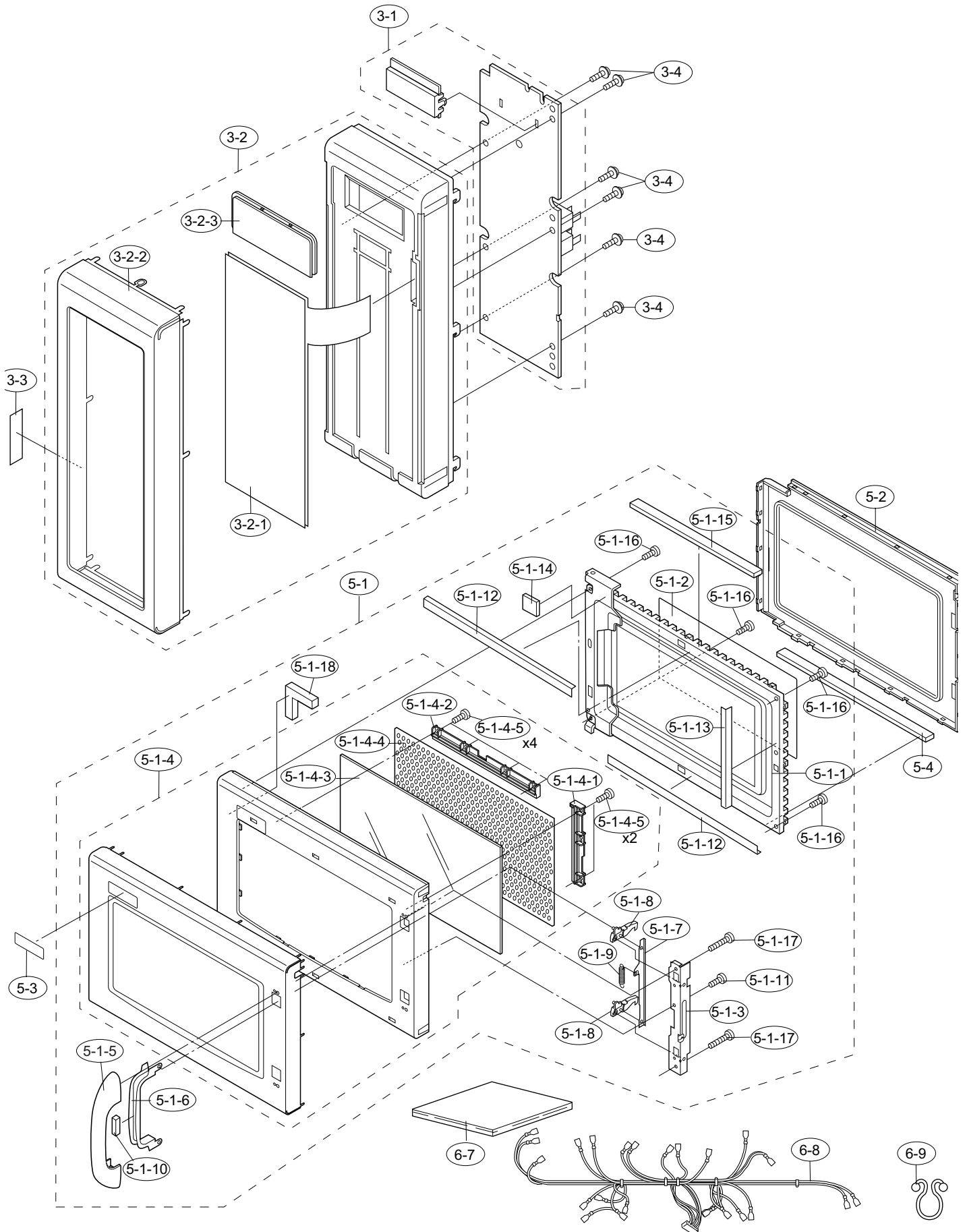

Actual wire harness may be different from illustration.

NO.	PARTS CODE	PRICE RANK	NEW MARK	PART RANK	DESCRIPTION
[2] DOOR AND CONTROL PANEL PARTS					
CONTROL PANEL PARTS					
3-1	DPWB-A417DRKZ	BQ			Control unit [R-21LTF]
3-1	DPWB-A418DRKZ	BQ			Control unit [R-21LVF]
3-2	FPNLCB912WRKZ	BB			Control panel frame with key unit [R-21LTF]
3-2	FPNLCB913WRKZ	BB			Control panel frame with key unit [R-21LVF]
3-2-1	FUNTKB173WREZ	AU			Key unit [R-21LTF]
3-2-1	FUNTKB174WREZ	AU			Key unit [R-21LVF]
3-2-2	GCOVAA260WRP0	BA			C/P case
3-2-3	GMADIA109WRF0	AE			Display window
3-3	TCAUAA076WRR0	AB			User caution label
3-4	XEPS730P08XS0	AA			Screw; 3mm x 8mm
DOOR PARTS					
* 5-1	CDORFB052WRKZ	BT			Door assembly
* 5-1-1	FDORFA322WRT0	AZ			Door panel assembly
5-1-2	PSHEPA649WRE0	AB			Sealer film
* 5-1-3	FANGKA206WRY0	AW			Latch angle assembly
* 5-1-4	FCOV-A012WRKZ	BQ			Door case assembly
5-1-4-1	LSTPPA180WRF0	AK			Glass stopper R
5-1-4-2	LSTPPA182WRF0	AN			Glass stopper U
5-1-4-3	PGLSPA516WRE0	AU			Front door glass
5-1-4-4	PSLDMA198WREZ	BB			Sealer plate
5-1-4-5	XETS740P08000	AA			Screw : 4mm x 8mm
5-1-5	GWAKPA580WRM0	AQ			Door handle
5-1-6	JHNDMA040WRW0	AN			Handle lever
* 5-1-7	LANGKA874WRW0	AR			Latch lever
* 5-1-8	LSTPPA181WRF0	AL			Latch head
5-1-9	MSPRTA190WRE0	AD			Latch spring
5-1-10	PCUSUA506WRP0	AC			Cushion
5-1-11	XEPS740P06000	AA			Screw : 4mm x 6mm
5-1-12	PSHEPA686WRE0	AK			Panel sheet
5-1-13	PSHEPA687WRE0	AK			Panel sheet
5-1-14	PCUSGA514WRP0	AK			Cushion
5-1-15	PCUSUA505WRP0	AC			Cushion
5-1-16	XEBS738P08000	AB			Screw : 3.8mm x 8mm
5-1-17	XEPS740P25K00	AC			Screw : 4mm x 25mm
5-1-18	PCUSUA508WRP0	AC			Cushion
* 5-2	GCOVHA407WRF0	AM			Choke cover
5-3	HBDGCA124WREZ	AK			Door badge [R-21LTF]
5-3	HBDGCA122WREZ	AK			Door badge [R-21LVF]
* 5-4	PPACGA171WRE0	AK			Cushion (ferrite)
MISCELLANEOUS					
6-7	TINSEB126WRRZ	AM			Instruction book
6-8	FW-VZC074WREZ	AX			Main wire harness
6-9	LHLDWA013WRE0	AC			Purse lock LL

INDEX

PARTS CODE	No.	PRICE RANK	NEW MARK	PART RANK	PARTS CODE	No.	PRICE RANK	NEW MARK	PART RANK
[C]									
CDORFB052WRKZ	2-5-1	BT			PF i LW A060WRP0	1-4-29		AD	
[D]					PGLSPA516WRE0	2-5-1-4-3		AU	
DPWB-A417DRKZ	2-3-1	BQ			PHOK-A160WRFZ	1-4-8		AN	
DPWB-A418DRKZ	2-3-1	BQ			PPACGA171WRE0	2-5-4		AK	
[F]					PSHEPA644WRE0	1-4-30		AD	
FACCD A116WREZ	1-1-4	AV			PSHEPA649WRE0	2-5-1-2		AB	
FANGKA206WRY0	2-5-1-3	AW			PSHEPA673WRE0	1-4-40		AD	
FCOV-A012WRKZ	2-5-1-4	BQ			PSHEPA674WRE0	1-4-38		AL	
FDORFA322WRT0	2-5-1-1	AZ			PSHEPA686WRE0	2-5-1-12		AK	
FDUC-A341WRY0	1-4-9	BL			PSHEPA687WRE0	2-5-1-13		AK	
FFS-BA033WRKZ	1-1-1	--			PSKR-A347WRW0	1-4-31		AL	
FGLSPA062WRE0	1-4-1	BL			PSKR-A348WRW0	1-4-16		AN	
FH-DZA119WRKZ	1-1-5	AU			PSKR-A349WRP0	1-4-32		AF	
FPLT-A007WRY0	1-4-14	BB			PSKR-A351WRP0	1-4-10		AY	
FPNLCB912WRKZ	2-3-2	BB			PSKR-A359WRW0	1-4-33		AM	
FPNLCB913WRKZ	2-3-2	BB			PSLDM A198WREZ	2-5-1-4-4		BB	
FPWBFA389WRKZ	1-1-8	AW			PSPA-A112WRE0	1-4-34		AC	
FPWBFA417WRKZ	1-1-8	AY			[Q]				
FUNTKB173WREZ	2-3-2-1	AU			QSOCLA021WRE0	1-1-9		AG	
FUNTKB174WREZ	2-3-2-1	AU			QSW-MA085WRE0	1-1-2		AF	
FW-VZC074WREZ	2-6-8	AX			QSW-MA135WRE0	1-1-3		AH	
[G]					[R]				
GCABUA672WRP0	1-2-1	BH			RC-QZA235WRE0	1-1-6		AU	
GCOVAA260WRP0	2-3-2-2	BA			RC-QZA336WRZZ	1-1-6		--	
GCOVHA406WRW0	1-2-3	AQ			RLMPTA086WRZZ	1-1-10		AL	
GCOVHA407WRF0	2-5-2	AM			RMOTDA233WRE0	1-1-11		AQ	
GCOVHA509WREZ	1-4-17	AG			RMOTEA376WRE0	1-1-7		AU	
GDA i -A311WRW0	1-2-2	AS			RTHM-A080WRE0	1-1-12		AP	
GLEGPA074WRE0	1-2-4	AC			RTHM-A096WRE0	1-1-13		AK	
GLEGPA076WRF0	1-2-5	AF			RTHM-A120WRE0	1-1-12		AH	
GMAD i A109WRF0	2-3-2-3	AE			RTHM-A123WRZZ	1-1-13		AK	
GWAKPA580WRM0	2-5-1-5	AQ			RTHM-A137WRZZ	1-1-13		AH	
[H]					RTHM-A138WRZZ	1-1-12		AH	
HBDGCA122WREZ	2-5-3	AK			RTRN-A751WRZZ	1-1-14		BP	
HBDGCA124WREZ	2-5-3	AK			RV-MZA347WRZZ	1-1-15		BH	
[J]					[T]				
JHNDMA040WRW0	2-5-1-6	AN			TCAUAA076WRR0	2-3-3		AB	
[L]					TCAUAA243WRR0	1-6-5		AC	
LANGFA199WRWZ	1-4-18	AH			TCAUAA245WRR0	1-6-6		AC	
LANGKA874WRW0	2-5-1-7	AR			TCAUAA249WRR0	1-6-2		AE	
LBNDKA136WRP0	1-4-11	AQ			TCAUAA250WRR0	1-6-3		AF	
LHLDWA013WRE0	2-6-9	AC			TCAUAA295WRRZ	1-6-4		AH	
LSTPPA180WRF0	2-5-1-4-1	AK			T iNSEB126WRRZ	2-6-7		AM	
LSTPPA181WRF0	2-5-1-8	AL			TMAPCA780WRRZ	1-6-1		AH	
LSTPPA182WRF0	2-5-1-4-2	AN			[X]				
LX-CZ0052WRE0	1-7-4	AA			XBPWW40P04000	1-7-6		AB	
LX-CZA038WRE0	1-7-3	AA			XEBS738P08000	2-5-1-16		AB	
LX-EZA042WRE0	1-7-5	AB			XEPS730P08XS0	2-3-4		AA	
[M]					XEPS740P06000	2-5-1-11		AA	
MLEVPA227WRF0	1-4-3	AF			XEPS740P25000	1-7-2		AB	
MLEVPA228WRF0	1-4-4	AF			XEPS740P25K00	2-5-1-17		AC	
MLEVPA229WRF0	1-4-5	AF			XETS740P08000	2-5-1-4-5		AA	
MSPRCA108WRE0	1-4-6	AC			XHPS730P06000	1-7-9		AB	
MSPRTA190WRE0	2-5-1-9	AD			XHPS740P08000	1-7-7		AB	
MSPRTA191WRE0	1-4-7	AC			XHPS740P08K00	1-7-1		AB	
[N]					XHTS740P08000	1-7-8		AC	
NFANJA029WRE0	1-4-12	AK			XHTS740P08RV0	1-7-10		AG	
NSFTPA035WRFZ	1-4-19	AQ			XOTS740P08000	1-7-12		AA	
[P]					XOTS740P12000	1-7-11		AA	
PCL i CA032WRE0	1-4-20	AD			XOTWW40P10000	1-7-13		AA	
PCL i CA033WRE0	1-4-21	AD							
PCOVPA344WRF0	1-4-22	AF							
PCOVPA345WRF0	1-4-23	AF							
PCUSGA249WRP0	1-4-24	AA							
PCUSGA378WRP0	1-4-35	AL							
PCUSGA504WRP0	1-4-15	AB							
PCUSGA514WRP0	2-5-1-14	AK							
PCUSUA194WRP0	1-4-26	AC							
PCUSUA505WRP0	2-5-1-15	AC							
PCUSUA506WRP0	2-5-1-10	AC							
PCUSUA507WRP0	1-4-36	AC							
PCUSUA508WRP0	2-5-1-18	AC							
PCUSUA511WRP0	1-4-25	AC							
PCUSUA514WRP0	1-4-27	AB							
PCUSUA517WRP0	1-4-37	AE							
PCUSUA518WRP0	1-4-39	AC							
PDUC-A888WRFZ	1-4-13	AM							
PDUC-A966WRFZ	1-4-28	AT							

SHARP

COPYRIGHT © 2006 BY SHARP CORPORATION

ALL RIGHTS RESERVED.

No part of this publication may be reproduced, stored in retrieval systems, or transmitted in any form or by any means, electronic, mechanical, photocopying, recording, or otherwise, without prior written permission of the publisher.